

# LF-II Series

LF2200 II Series | LF2600 II Series

HYUNDAI WIA Front Loading Turning Center

# Technical Leader

## Twin Spindle, Front Loading CNC Turning Center

LF-II Series features high mobility through its compact size, making it suitable for tight spaces, and automated operations for maximizing productivity.

Model	Chuck			Guideway		Standard Turret			Mill Turret	
	6"	8"	10"	Roller	Box	8 Station	10 Station	12 Station	10 Station	12 Station
LF2200 II	○	○			●	●	○			
LF2200Quick II	○	○		●		●	○			
LF2200M II	○	○			●				●	
LF2200MQuick II	○	○		●					●	
LF2600 II		○	○		●		●	○		
LF2600Quick II		○	○	●			●	○		
LF2600M II		○	○		●				●	○
LF2600MQuick II		○	○	●					●	○

● Standard ○ Option

# LF-II

## Series

Front Loading Turning Center with Top Global Standard

- Increased rigidity by improving Z-axis structure
- Selection between roller LM guide and box guide way
- Stable unit composition with minimized thermal deformation
- Various types of gantry loader ensure effective & flexible automation
- A pleasant working environment by improving chip disposal ability
- Enhanced convenience by applying Fanuc's latest controller



# 01 BASIC STRUCTURE

Optimized Layout and Design, Twin Spindle Front Loading CNC Turning Center

## Turret

- Tool Size (O.D | I.D.)  
 LF2200 II Series :  $\varnothing 20$  |  $\varnothing 32$  mm ( $\varnothing 3/4$ " |  $\varnothing 1 1/4$ " )  
 LF2600 II Series :  $\varnothing 25$  |  $\varnothing 40$  mm ( $\varnothing 1$ " |  $\varnothing 1 1/2$ " )
- Mill Turret  
 LF2200M II Series : BMT45 : 6,000 r/min  
 LF2600M II Series : BMT55 : 5,000 r/min

## High Precision Spindle

- LF2200 II Series  
 [6" : 6,000 r/min | 8" : 4,500 r/min]
- LF2600 II Series  
 [8" : 4,000 r/min | 10" : 3,500 r/min]
- C-Axis Control : 0.001° (\*M' Type)

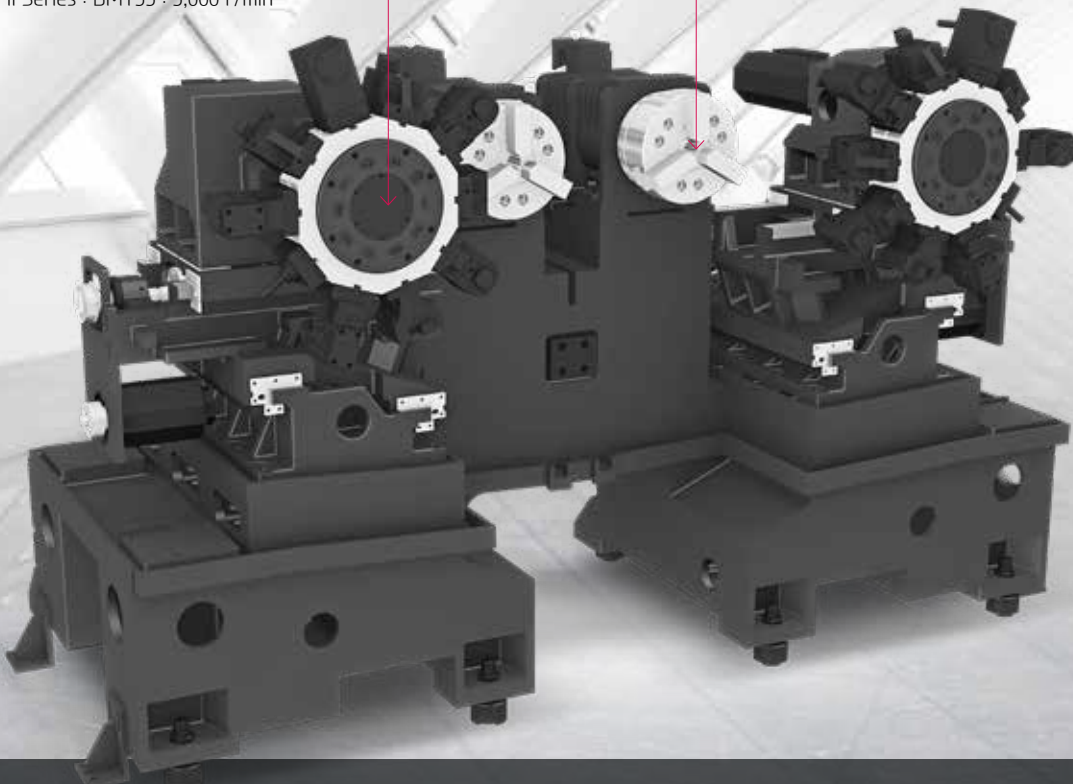

## Increased Rigidity by Changing the Bed Structure

In order to prevent decreased rigidity caused by load imbalance from sagging of the turret, and reduced lifetime of the give, LF2600 II Series increased the rigidity and realized high-precision product machining by designing protruded spindle headstock and Z-axis tool post.

### ◎ Reduced Protruded Length of Tool Post

LF2200 II Series : 390 mm (15.4") > 257 mm (10.1") - 133 mm (5.2") shorter

LF2600 II Series : 507 mm (20") > 269 mm (10.6") - 238 mm (9.4") shorter

<Previous Machine>

<LF-II Series>

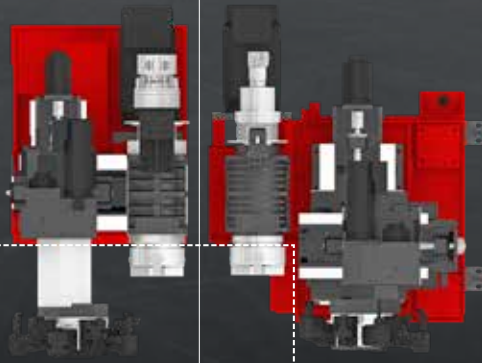

# POWERFUL CUTTING CAPABILITY & LARGE WORKING AREA

## HIGH PRECISION STRUCTURE

### Separated Bed Structure

The LF-II series is designed as a separated bed structure, minimizing thermal growth and vibration, ensuring stable cutting capability.

### Z-axis Structure

Prevent sagging of the turret by reducing the protruded parts of the headstock by changing the structure of the Z-axis, and allow for high-precision machining of the product by increasing rigidity.

<Secure rigidity through shortest possible design of the outer guideway to the spindle>

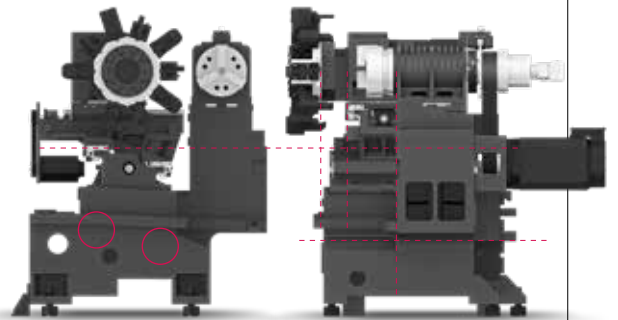

**Get Close to the Spindle of the Cascaded Z-axis and Expand Span > Increased Rigidity**

## GUIDEWAY

### Roller LM Guide / Box Guide

The transfer axis of LF-II Series give options for roller LM guide and box guide to ensure optimum conditions according to machining characteristics.

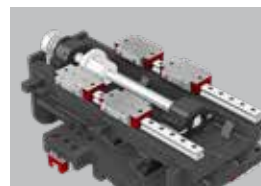

<Roller Guide - Quick Type>



<Box Guide>

### Ball Screw

In order to eliminate thermal growth and to increase accuracy, all axes are driven by high precision double anchored ballscrews.



### Rapid Traverse Rate (X/Z)

Roller LM Guideway (LF2200/2600Quick II Series)

**24/36** m/min (945/1,417 ipm)

Box Guideway (LF2200/2600 II Series)

**24/24** m/min (945/945 ipm)

### Travel (X/Z)

LF2200 II Series

**140/170** mm (5.5"/6.7")

LF2600 II Series

**190/200** mm (7.5"/7.9")

LF-II SERIES

# 02 MACHINING PERFORMANCE

Excellent Performance, High Precision - Front Loading Turning Center



WHEEL HUB



COOLING ADAPTER

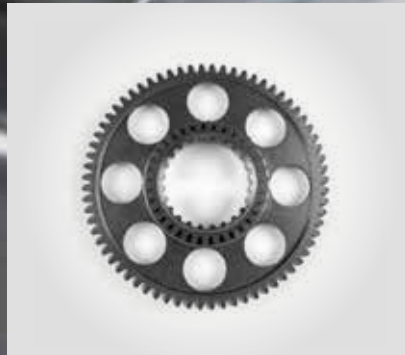

DRIVE GEAR

## MACHINING PROCESS WITH ONLY ONE INITIAL SETTING

### REDUCED MACHINING TIME BY HYUNDAI WIA'S TECHNIQUE

LF II Series features a compact structure for the convenience in applying components and an automated system with improved productivity. In addition, an optimized design of a high-rigidity bed, spindle and guide realizes high-precision product processing by reducing complex thermal deformation.

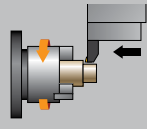

**O.D Turning**  
(Material : S45C)

	LF2200M II	LF2600M II
Machining depth	4 mm (0.16")	4 mm (0.16")
Spindle rpm	1,078 rpm	796 rpm
Cutting speed	210 m/min	210 m/min
Forwarding speed	0.48 mm/rev	0.5 mm/rev
Chip discharging amount	403 cc/min	420 cc/min

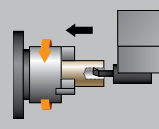

**Boring**  
(Material : S45C)

	LF2200M II	LF2600M II
Machining depth	3 mm (0.12")	3 mm (0.12")
Spindle rpm	1,500 rpm	1,326 rpm
Cutting speed	180 m/min	250 m/min
Forwarding speed	0.3 mm/rev	0.3 mm/rev
Max. boring depth	3.5 times of boring bar dia.	4 times of boring bar dia.

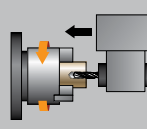

**U-Drill**  
(Material : S45C)

	LF2200M II	LF2600M II
Tool Dia.	Ø32 mm (Ø1 1/4")	Ø40 mm (Ø1 1/2")
Spindle rpm	1,035 rpm	828 rpm
Cutting Speed	104 m/min	104 m/min
Forwarding speed	0.3 mm/rev	0.3 mm/rev
Chip discharging amount	250 cc/min	312 cc/min

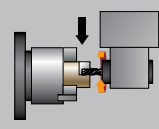

**End Mill**  
(Material : S45C)

	LF2200M II	LF2600M II
Tool Dia.	Ø12 mm (Ø1/2")	Ø16 mm (Ø5/8")
Tool Rotation Speed	1,000 rpm	1,580 rpm
Cutting Speed	100 m/min	76 m/min
Forwarding speed	0.1 mm/rev	0.165 mm/rev
Machining depth	12 mm	16 mm

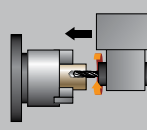

**Drill**  
(Material : S45C)

	LF2200M II	LF2600M II
Tool Dia.	Ø12 mm (Ø1/2")	Ø16 mm (Ø5/8")
Tool Rotation Speed	2,758 rpm	1,580 rpm
Forwarding speed	0.18 mm/rev	0.35 mm/rev
Cutting speed	104 m/min	80 m/min

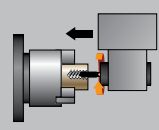

**Tapping**  
(Material : S45C)

	LF2200M II	LF2600M II
Tool Dia.	M12	M20
Tool Rotation Speed	133 rpm	88 rpm
Forwarding speed	1.75 mm/rev	2.5 mm/rev
Cutting speed	5 m/min	5 m/min

❖ The above result might be different by types of processing circumstances.

# 03 HIGH PRECISION SPINDLE

Long Lasting, High Accuracy & Excellent Performance CNC Turning Center

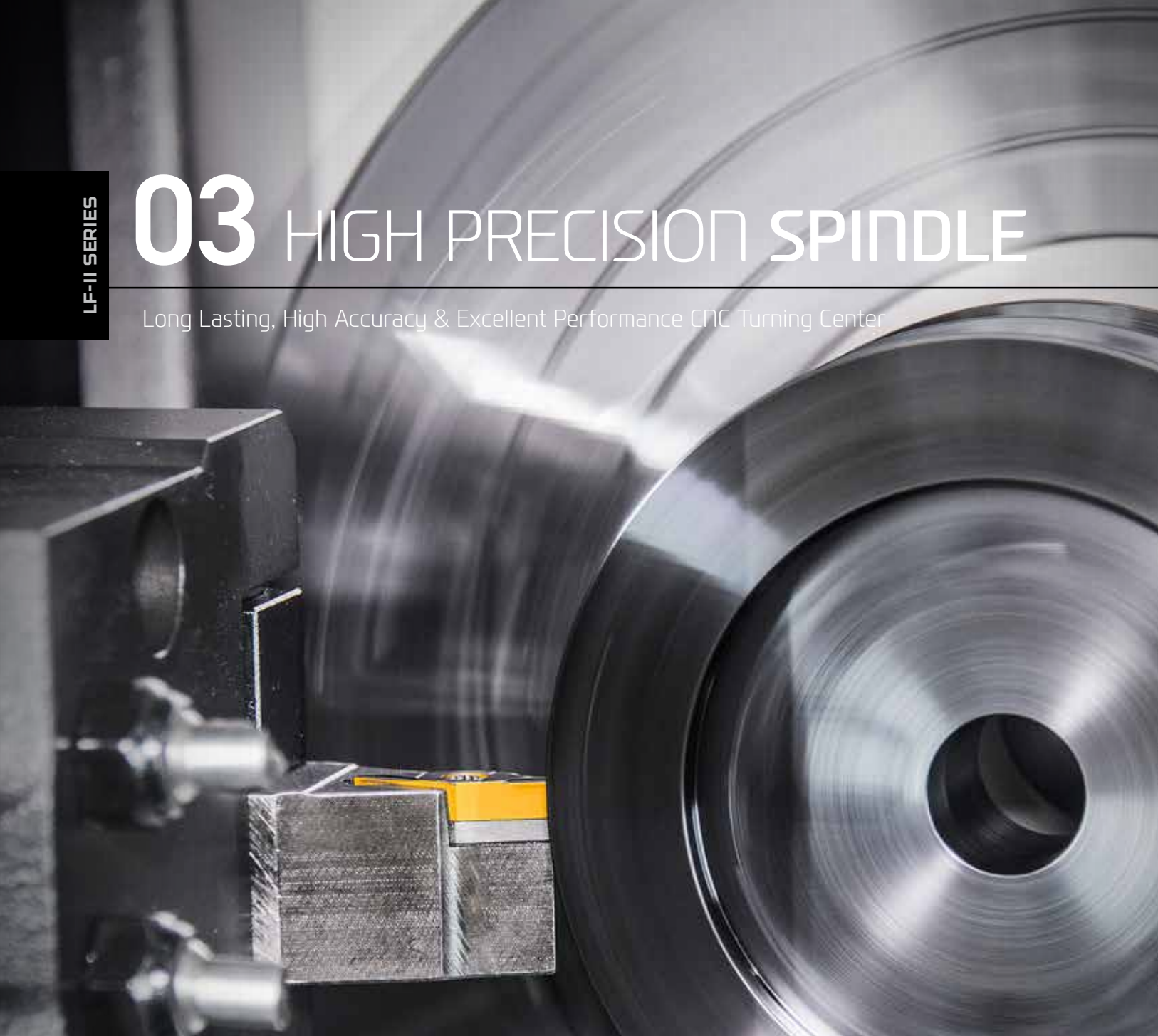

## LF2200 II Series – Spindle Specifications

● : High-Torque

Chuck Size	Distance Between the Sp.	Spindle Speed	Motor (Max./Cont.)	Torque (Max.)	Spindle Nose
Opt : 6"	370 mm (14.6")	6,000 rpm	15/11 kW (20/15 HP)	127 N·m (93.7 lbf-ft)	A2-5
Opt : 8"		4,500 rpm			

## LF2600 II Series – Spindle Specifications

Chuck Size	Distance Between the Sp.	Spindle Speed	Motor (Max./Cont.)	Torque (Max.)	Spindle Nose
Opt : 8"	450 mm (17.7")	4,000 rpm	15/11 kW (20/15 HP)	245.5 N·m (187.7 lbf-ft)	A2-6
Opt : 10"		3,500 rpm	18.5/15 kW (25/20 HP)	403 N·m (297.2 lbf-ft)	



# HEAVY DUTY CUTTING & HIGH ACCURACY

## SPINDLE

### Spindle for Heavy Cutting

The spindle has the highest speed and torque in its class, which provides high performance during high speed/heavy duty cutting. Also the spindle is designed with [Ø110 (Ø4.3")] size P4 angular contact ball bearings to minimize thermal displacement and increase accuracy.

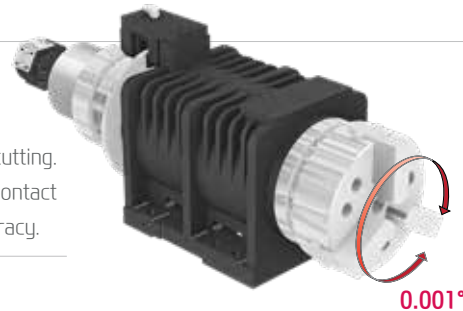

### C-Axis Control ("M" Type)

C-axis of LF2600M II can be controlled to 0.001° which makes it possible to process various shapes.

### Greatly Increased Ability of Simultaneous Interrupted Machining of Right/Left Sides

R/L covers are separately designed to minimize the transfer of vibrations between equipment from interrupted machining or rough machining.

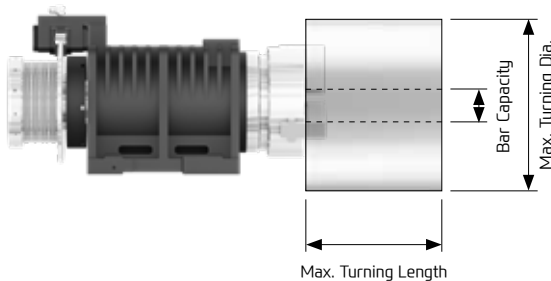

ITEM	LF2200 II Series	LF2600 II Series
Max. Turning Length	170mm (6.7")	200mm (7.9")
Bar Capacity	Ø45mm (Ø1.8")	Ø65mm (Ø2.6")
Max. Turning Dia.	Ø260mm (Ø10.2")	Ø360mm (Ø14.2")

## SPINDLE PROCESSING FLOW

- 01** Parts requiring secondary operations are transferred from Z1 spindle to Z2 spindle
- 02** Same parts can be processed simultaneously by utilizing both spindles of Z1/Z2-axis with same parts.
- 03** Different parts can be processed simultaneously by utilizing both spindles of Z1/Z2-axis with various parts.



# 04 SERVO TURRET

High speed, High Accuracy, Highly Reliable Servo Turret

## Standard Turret Specifications

Model	No. of Tools	Tool Size (O.D/I.D)	Indexing Time
LF2200 II Series	8 [10] EA	□ 20/Ø32 mm (□ 3/4"/Ø1 1/4")	0.1 sec
LF2600 II Series	10 [12] EA	□ 25/Ø40 mm (□ 1"/Ø1 1/2")	

## Mill Turret Specifications

Model	Speed rpm	Power (Max./Cont)	Torque (Max./Cont)	Type
LF2200M II Series	6,000 r/min	2.75/1.85 kW [3.7/2.5 HP]	26.2/11.9 N·m [19.3/8.8 lbf-ft]	BMT45
LF2600M II Series	5,000 r/min	5.5/3.7 kW [7.4/5 HP]	52.5/26 N·m [38.7/9.2 lbf-ft]	BMT55

# VARIOUS DRIVEN PRECISION BMT TOOL HOLDERS

## TURRET

### Servo Turret

The turret of LF-II Series is applied with high performance AC servo motor, improving machining reliability. 3-piece coupling shows excellent performance in indexing. Moreover, powerful hydraulic hydraulic tool clamping minimizes tool tip deviation caused by load.

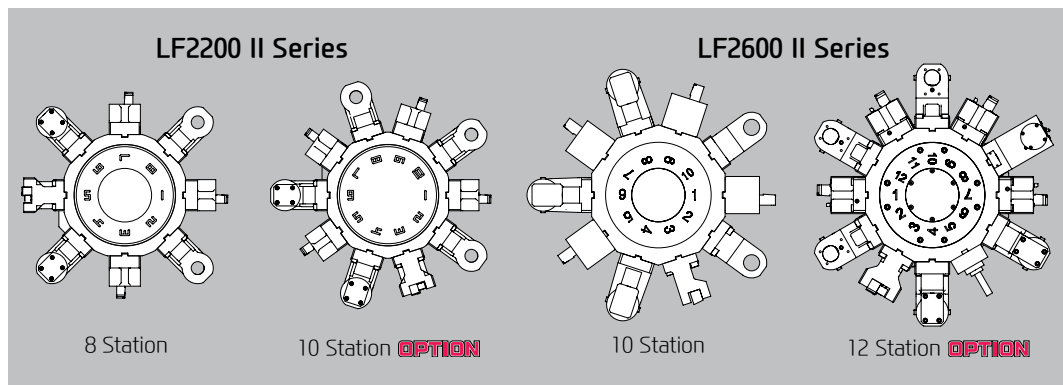

## MILL TURRET

### BMT Turret ('M' Type)

The BMT turret secures the tool with four bolts and key on the tool mounting surface of the turret, making it possible to powerfully fix the tool, ensuring high reliability in rigidity and precision.

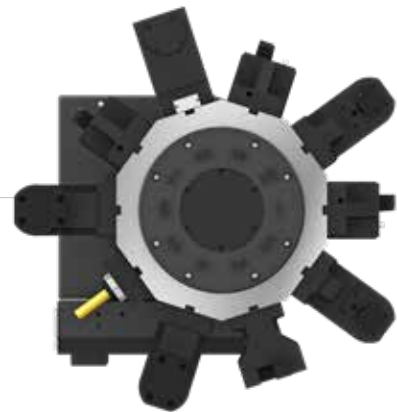

STRAIGHT MILLING HEAD



ANGULAR MILLING HEAD



### Mill Tool Holder

Machining capability has increased with the addition of straight milling head tool holder, which can machine workpieces from the side, and angular milling head tool holder, which can perform I.D. operations.

# 05 GANTRY AUTOMATION

Various Devices for User Convenience

**LF2200 II (3+3 kg)**

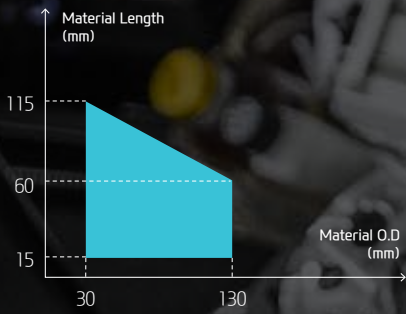

**LF2600 II (6+6 kg)**

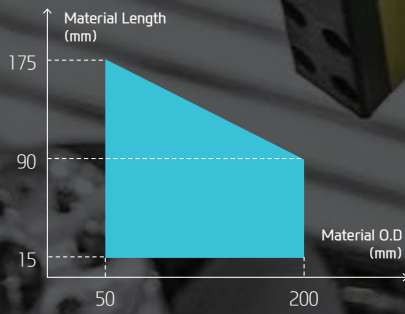

**LF2600 II (10+10 kg)**

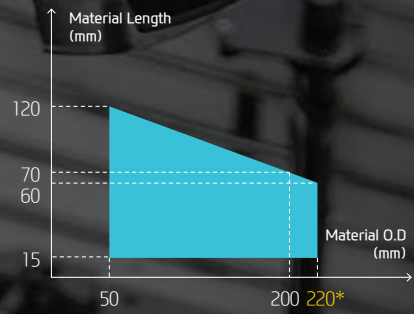

Ø220\* : Workstocker special production (Sales Inquiries)

Model	Swivel Unit	Max. Handling Products
LF2200M II Series	3+3 kg (6.6+6.6 lb)	Ø130 × L60 mm (Ø5.1" × L2.4")
LF2600M II Series	6+6 kg (13.2+13.2 lb)	Ø200 × L90 mm (Ø7.9" × L3.5")
	10+10 kg (22+22 lb)	Ø200 × L70 mm (Ø7.9" × L2.8")

# GANTRY LOADER SYSTEM

Gantry loader transfers raw material from in-stocker to machine automatically, starting machining process. Gantry automation provides good equipment access during operation and easy work monitoring, program modification and maintenance. In addition, small installation area facilitates optimized factory layout.

## Gantry Specifications

Max. Work Weight	3 kg (6.6 lb)	6 kg (13.2 lb)
Gantry Speed	X-axis	210 m/min
	Y-axis	180 m/min
	Z-axis	60 m/min
Loading Time	5.7 sec	7.8 sec

- ❖ LF2200 II can only work with 3kg.
- ❖ The above loading time may vary depending on changes in the weight of the workpiece.

## Stocker Specifications

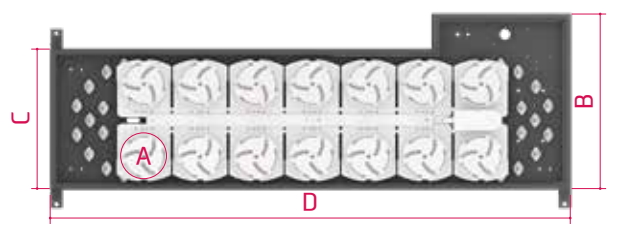

☆ Sales Inquiry

Model	LF2200 II	LF2600 II
Work Size	Ø120 (Ø4.7")	Ø180 (Ø7.1")
Max. Work Weight	35 kg (77.2 lb) / Pallet	
No. of Pallet (EA)	Ellipse Type : 10, 12, 14, 16 / Ring Type : 8	
Dimensions (A/B/C)	Ø200/790/620 mm (Ø7.9"/31.1"/24.4")	Ø220/850/680 mm (Ø8.7"/33.5"/26.8")
Pallet (D)	10EA	1,830 mm (72")
	12EA	2,060 mm (81.1")
	14EA	2,270 mm (89.4")
	16EA	2,480 mm (97.6")
		2,790 mm (109.8")

## Separated Gantry

The gantry is completely separated from the R/L bed to minimize the transfer of vibrations between equipment during interrupted machining or gantry operation. (Ask our sales personnel.)

- ❖ Side Beam (Optional)

# Customized Gantry Loader

Consists of 5 default types to meet various customer needs. (Ask to sales associates for the details)

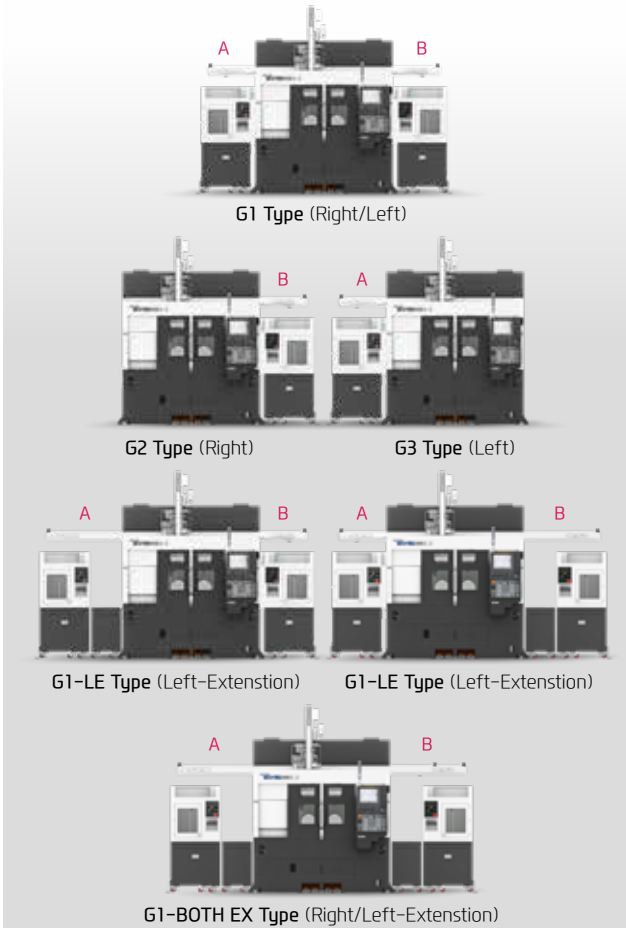

ITEM	Travel			Dimensions	
	X-axis	Y-axis	Z-axis	A	B
G1				450 (17.7")	450 (17.7")
G2	3,260 (128.3")	700 (27.6")	310 (12.2")	-	800 (31.5")
G3				800 (31.5")	-
G1-RE	3,920 (154.3")			450 (17.7")	1,110 (43.7")
G1-LE				1,110 (43.7")	450 (17.7")
G1-BOTH EX	4,580 (180.3")			1,110 (43.7")	1,110 (43.7")

# 06 USER CONVENIENCE

Various Devices for User Friendly



## CHIP DISPOSAL SOLUTION

### 1. Separation of Coolant Tank

You can separate only the coolant tank without separating the chip conveyor.

### 2. Sliding Separate Cover

A forward/backward sliding method allows a broader work space to be secured, leading to excellent maintainability.

### 3. Improved Chip Removal Convenience

It is designed with an opening to easily remove chips, waste oil and the chip filter from the front of the equipment.

### 4. Automatic Removal of Chips on Top of Equipment

It comes with an automatic brushing function for the removal of residuals such as chips/debris building up on the top of the equipment and a lateral chip tray that can be removed to maintain cleanliness on top by removing debris and residuals.

### Side Chip Conveyor (G2/G3 Type)

If there is not enough installation space in the back, you can install side-type chip conveyor. <If side-type chip conveyor is applied, only 1 stalker may be applied.>

Hinge	Roughing, Long chip, chip complex
Scraper	Finely broken chip blown out
Screw	The lower portion of micro-chips
Drum Filter	Powder, micro chip

Optional

## COOLANT UNIT

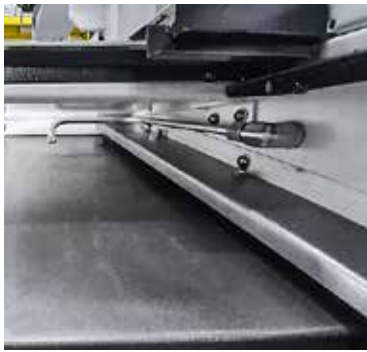

### Bed Flushing Coolant

Bed flushing coolant is applied on top and bottom of the Z-axis slide as a default to easily process residual chips.



Standard Coolant (Nozzle)

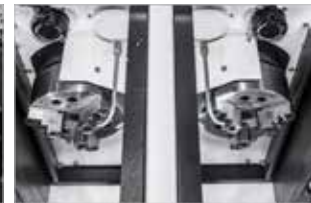

Chuck Coolant (Upper Chuck)



Gun Coolant



Air Gun

## HIGH PRECISION SYSTEM



### Removable-type Q-Setter

Cutting tools are calibrated quickly and accurately with the addition of a Q-setter. Each tool tip is touched off manually using a sensor that inputs the position automatically.



### Linear Scale

Linear scales increase positioning accuracy and reduce distortion caused by thermal growth, thus ensuring a more accurate finished part.



### Work Probe

Workpiece coordinate values can be set automatically using the optional spindle probe.

# 07 HYUNDAI WIA FANUC – SMART PLUS

The Compatible All-round Control



**15" Touch-type Monitor as a standard**

- Fast Cycle Time Technology
- Smart Machine Control
- Conversational Program
- i-HMI
- Part Program Storage
- No. of Registerable Programs
- Fine Surface Technology
- Smart Servo Control Technology
- SmartGuide-i
- Machining-aid Function
- 5120M (2MB)
- 1000 EA

## HW-GLM (HYUNDAI WIA Gantry Loader Manager)

Set the position coordinates and the loader driver support features such as easy and convenient way to provide the user operating the loader to be used to support the software.

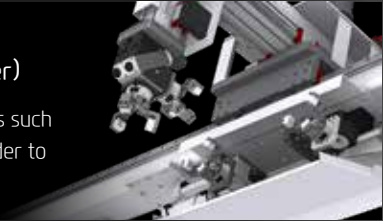



## ACAM (Automatic CAM)

Cloud-based automatic CAM S/W that automatically creates NC programs only by inputting drawing files

Cloud-based Intelligent Programming

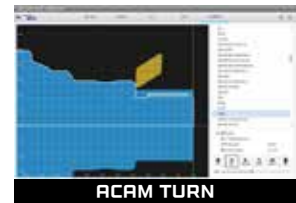
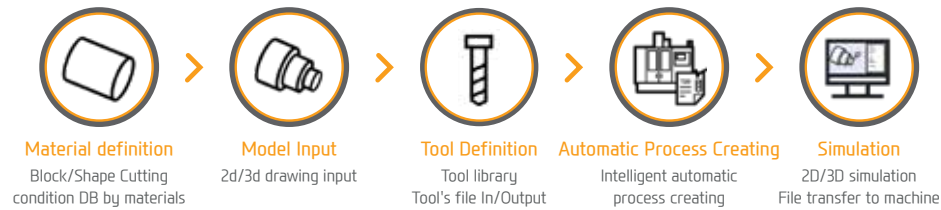

## MMS (Machine Monitoring System)



### 1. MMS Cloud

A cloud server-based equipment monitoring system for collecting and analyzing facility operation data.

### 2. MMS Edge

A client server-based tool monitoring system for collection/analysis of facility operation data. (Compatible with client MES / ERP interface)

## SMART CNC (FANUC SMART PLUS)

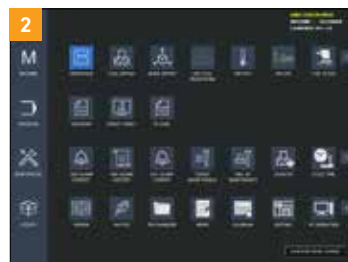

### 1. Dialogue Program (Smart Guide-i)

This software offers the maximum user convenience through dialogue manipulation from setup to processing. This includes writing processing programs and simulation checks.

### 2. LAUNCHER

This software offers shortcuts for quick access to specialized features and frequently used features.

# SPECIFICATIONS

## Standard & Optional

● : Standard ○ : Option ☆ : Prior Consultation - : Non Applicable

Spindle		LF2200 II Series	LF2200M II Series
Main Spindle	6"	○	○
Hollow Chuck 3 Jaw	8"	○	○
Main Spindle	6"	○	○
Solid Chuck 3 Jaw	8"	○	○
Without Chuck		●	●
Standard Soft Jaw (1 set)		○	○
2 Steps Hyd. Pressure Device		○	○
2 Steps Foot Switch		○	○
2 Steps Hyd. Pressure Device		○	○
Spindle Inside Stopper		☆	☆
Chuck Open/Close Confirmation Device		●	●
Main Spindle 5° Index		☆	☆
Cs-Axis (0.001°)		-	●
<b>Turret</b>			
Tool Holder		●	●
Mill Turret	BMT	-	●
Straight Milling Head (Axial)	Collet Type, 2ea	-	●
Angular Milling Head (Radial)	Collet Type, 2ea	-	●
Straight Milling Head (Axial)	Adapter Type	-	○
Angular Milling Head (Radial)	Adapter Type	-	○
Boring Sleeve		●	●
Drill Socket		○	○
U-Drill Holder		●	●
O.D Extension Holder	For Out-Dia	☆	☆
Angle Head		-	☆
<b>Coolant &amp; Air Blow</b>			
Standard Coolant (Nozzle)		●	●
Chuck Coolant (Upper Chuck)		○	○
Bed Flushing Coolant		●	●
Gun Coolant		○	○
Through Spindle Coolant (Only for Special Chuck)		☆	☆
Turnmill Through Coolant		-	☆
Chuck Air Blow		○	○
Tail Stock Air Blow		☆	☆
Air Gun		○	○
Through Spindle Air Blow (Only for Special Chuck)		☆	☆
High Pressure Coolant	1.5Bar	●	●
	6Bar	○	○
	10Bar	○	○
Power Coolant System (For Automation)		☆	☆
Coolant Chiller		☆	☆
<b>Chip Disposal</b>			
Coolant Tank	255 ℓ	●	●
Chip Conveyor	Front (Rear)	○	○
(Hinge/Scraper/Screw)	Front (Right)	○	○
Special Chip Conveyor (Drum Filter)		☆	☆
Chip Wagon	Standard (180 ℓ [47.5 gal])	○	○
	Swing (200 ℓ [52.8 gal])	○	○
	Large Size (330 ℓ [87.2 gal])	○	○
	Customized	☆	☆
<b>Safety Device</b>			
Total Splash Guard		●	●
Chuck Hydraulic Pressure Maintenance Interlock		●	●
<b>Hyd. Device</b>			
Standard Hyd. Cylinder	Hollow	●	●
	Solid	○	○
Standard Hyd. Unit	35bar(507.6psi) / 15 ℓ (4gal)	●	●
<b>Environment</b>			
Air Conditioner		○	○
Oil Mist Collector		○	○
Oil Skimmer (Only for Chip Conveyor)		○	○
MQL (Minimum Quantity Lubrication)		☆	☆

Electric Device		LF2200 II Series	LF2200M II Series
Call Light	1Color : ●	●	●
Call Light & Buzzer	3Color : ● ● ● B	○	○
Electric Cabinet Light		○	○
Remote MPG		○	○
Work Counter	Digital	○	○
Total Counter	Digital	○	○
Tool Counter	Digital	○	○
Multi Tool Counter	Digital	○	○
Electric Circuit Breaker		○	○
AVR (Auto Voltage Regulator)		☆	☆
Transformer	40kVA	○	○
Auto Power Off		○	○
<b>Measurement</b>			
Manual Q-Setter (Basic)		☆	☆
Manual Q-Setter (Renishaw)		○	○
Automatic Q-Setter (Renishaw)		-	-
Work Close Confirmation Device (Only for Special Chuck)	TACO	☆	☆
	SMC	☆	☆
Work Setter		☆	☆
Linear Scale	X axis	○	○
	Z axis	○	○
Coolant Level Sensor (Only for Chip Conveyor)		☆	☆
Measurement System for Automation		☆	☆
<b>Fixture &amp; Automation</b>			
Auto Door		○	○
Auto Shutter		○	○
Sub Operation Pannel		☆	☆
Bar Feeder Interface		-	-
Bar Feeder (FEDEK)		-	-
Extra M-Code 4ea		○	○
Automation Interface		○	○
I/O Extension (IN & OUT)	16 Contact	○	○
	32 Contact	○	○
<b>Turret Work Pusher (For Automation)</b>			
		○	○
Gantry Automation	G1 (Both)	○	○
	G2 (Right)	○	○
	G3 (Left)	○	○
	G1-RE	○	○
	G1-LE	○	○
	G1-BOTH EX	○	○
Gantry Swivel Unit	3kg	○	○
	6kg	-	-
In/Out Stocker (Ellipse Type) 10/12/14/16 Pos		○	○
In/Out Stocker (Ring Type) 8/10/12/14 Pos		☆	☆
Turn Over		○	○
ΠG Chute		○	○
Gantry Side Beam		○	○
<b>S/W</b>			
Automatic CAM (HW-ACAM)		-	-
Dialogue Program (HW-DPRO)		○	○
DNC software (HW-eDNC)		○	○
Machine Monitoring System (HW-MMS Cloud)		☆	☆
Machine Monitoring System (Customer Installation : HW-MMS Edge)		☆	☆
Smart Guide-i : FANUC		●	●
Smart S/W		☆	☆
<b>ETC</b>			
Tool Box		●	●
Customized Color	Need Munsell No.	☆	☆
CAD & CAM		☆	☆

❖ Thermal Displacement Compensation device is recommended, when more than 6 bar of high pressure coolant is applied, for the high quality machining.

Specifications are subject to change without notice for improvement. / Please refer to the S/W catalog (IRIS) for details by S/W product.

# SPECIFICATIONS

## Standard & Optional

● : Standard ○ : Option ☆ : Prior Consultation - : Non Applicable

Spindle		LF2600 II Series	LF2600M II Series
Main Spindle	8"	○	○
Hollow Chuck 3 Jaw	10"	○	○
Main Spindle	8"	○	○
Solid Chuck 3 Jaw	10"	○	○
Without Chuck		●	●
Standard Soft Jaw (1set)		○	○
2 Steps Hyd. Pressure Device		○	○
2 Steps Foot Switch		○	○
2 Steps Hyd. Pressure Device		○	○
Spindle Inside Stopper		☆	☆
Chuck Open/Close Confirmation Device		●	●
Main Spindle 5° Index		☆	☆
Cs-Axis (0.001°)		-	●
<b>Turret</b>			
Tool Holder		●	●
Mill Turret	BMT	-	●
Straight Milling Head (Axial)	Collet Type, 2ea	-	●
Angular Milling Head (Radial)	Collet Type, 2ea	-	○
Straight Milling Head (Axial)	Adapter Type	-	○
Angular Milling Head (Radial)	Adapter Type	-	○
Boring Sleeve		●	●
Drill Socket		●	●
U-Drill Holder		●	●
O.D Extension Holder	For Out-Dia	☆	☆
Angle Head		-	☆
<b>Coolant &amp; Air Blow</b>			
Standard Coolant (Nozzle)		●	●
Chuck Coolant (Upper Chuck)		○	○
Bed Flushing Coolant		○	○
Gun Coolant		○	○
Through Spindle Coolant (Only for Special Chuck)		☆	☆
Turnmill Through Coolant		-	☆
Chuck Air Blow		○	○
Tail Stock Air Blow		☆	☆
Air Gun		○	○
Through Spindle Air Blow (Only for Special Chuck)		☆	☆
High Pressure Coolant	4.5Bar	●	●
	6Bar	○	○
	10Bar	○	○
Power Coolant System (For Automation)		☆	☆
Coolant Chiller		☆	☆
<b>Chip Disposal</b>			
Coolant Tank	255 ℓ	●	●
Chip Conveyor	Front (Rear)	○	○
(Hinge/Scraper/Screw)	Front (Right)	○	○
Special Chip Conveyor (Drum Filter)		☆	☆
Chip Wagon	Standard (180 ℓ [47.5 gal])	○	○
	Swing (200 ℓ [52.8 gal])	○	○
	Large Size (330 ℓ [87.2 gal])	○	○
	Customized	☆	☆
<b>Safety Device</b>			
Total Splash Guard		●	●
Chuck Hydraulic Pressure Maintenance Interlock		●	●
<b>Hyd. Device</b>			
Standard Hyd. Cylinder	Hollow	●	●
	Solid	○	○
Standard Hyd. Unit	35bar (507.6psi) / 15 ℓ (4gal)	●	●
<b>Environment</b>			
Air Conditioner		○	○
Oil Mist Collector		○	○
Oil Skimmer (Only for Chip Conveyor)		○	○
MQL (Minimum Quantity Lubrication)		☆	☆

Electric Device		LF2600 II Series	LF2600M II Series
Call Light	1Color : ●	●	●
Call Light & Buzzer	3Color : ● ● ● B	○	○
Electric Cabinet Light		○	○
Remote MPG		○	○
Work Counter	Digital	○	○
Total Counter	Digital	○	○
Tool Counter	Digital	○	○
Multi Tool Counter	Digital	○	○
Electric Circuit Breaker		○	○
AVR (Auto Voltage Regulator)		☆	☆
Transformer	40kVA	○	○
Auto Power Off		○	○
<b>Measurement</b>			
Manual Q-Setter (Basic)		☆	☆
Manual Q-Setter (Renishaw)		○	○
Automatic Q-Setter (Renishaw)		-	-
Work Close Confirmation Device (Only for Special Chuck)	TACO	☆	☆
	SMC	☆	☆
Work Setter		☆	☆
Linear Scale	X axis	○	○
	Z axis	○	○
Coolant Level Sensor (Only for Chip Conveyor)		☆	☆
Measurement System for Automation		☆	☆
<b>Fixture &amp; Automation</b>			
Auto Door		○	○
Auto Shutter		○	○
Sub Operation Panel		☆	☆
Bar Feeder Interface		-	-
Bar Feeder (FEDEK)		-	-
Extra M-Code 4ea		○	○
Automation Interface		○	○
I/O Extension (IN & OUT)	16 Contact	○	○
	32 Contact	○	○
Turret Work Pusher (For Automation)		○	○
Gantry Automation	G1 (Both)	○	○
	G2 (Right)	○	○
	G3 (Left)	○	○
	G1-RE	○	○
	G1-LE	○	○
	G1-BOTH EX	○	○
Gantry Swivel Unit	3kg	○	○
	6kg	○	○
In/Out Stocker (Ellipse Type) 10/12/14/16 Pos		○	○
In/Out Stocker (Ring Type) 8/10/12/14 Pos		☆	☆
Turn Over		○	○
TIG Chute		○	○
Gantry Side Beam		○	○
<b>S/W</b>			
Automatic CAM (HW-ACAM)		-	-
Dialogue Program (HW-DPRO)		○	○
DFC software (HW-eDFC)		○	○
Machine Monitoring System (HW-MMS Cloud)		☆	☆
Machine Monitoring System (Customer Installation : HW-MMS Edge)		☆	☆
Smart Guide-i : FANUC		●	●
Smart S/W		☆	☆
<b>ETC</b>			
Tool Box		●	●
Customized Color	Need Munsell No.	☆	☆
CAD & CAM		☆	☆

◆ Thermal Displacement Compensation device is recommended, when more than 6 bar of high pressure coolant is applied, for the high quality machining.

Specifications are subject to change without notice for improvement. / Please refer to the S/W catalog (iRS) for details by S/W product.

# SPECIFICATIONS

## Spindle Output/Torque Diagram

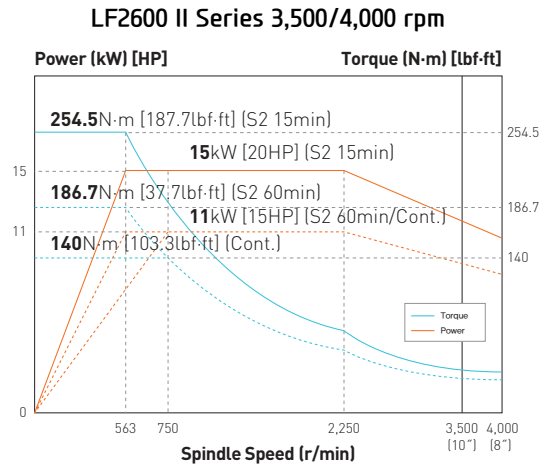
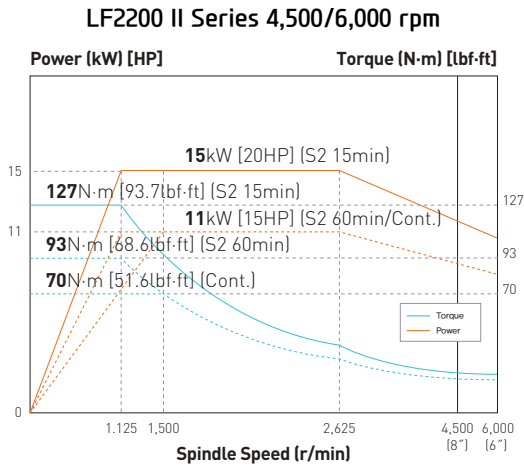

### LF2600 II Series 3,500/4,000 rpm (High-Torque)

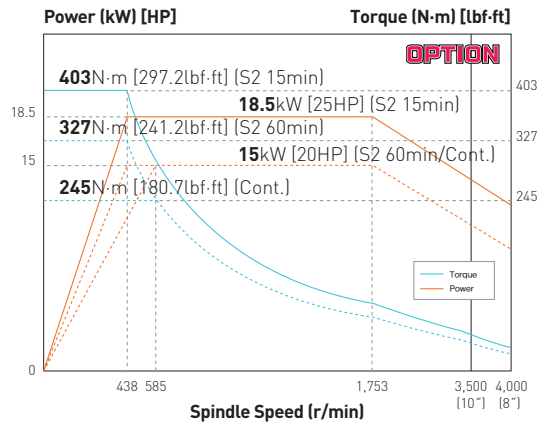

### LF2200M II Series Mill Turret 6,000 rpm

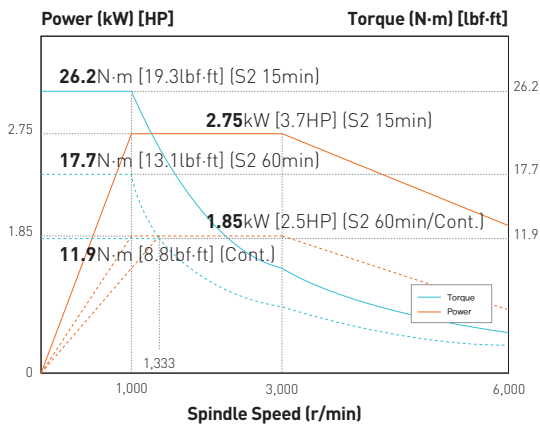

### LF2600M II Series Mill Turret 5,000 rpm

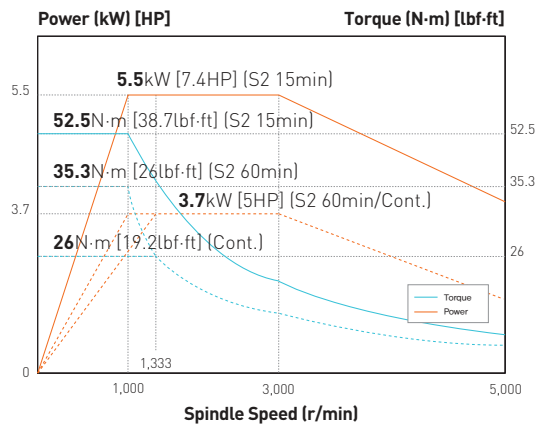

# SPECIFICATIONS

## External Dimensions

unit : mm(in)

### LF2200 II Series

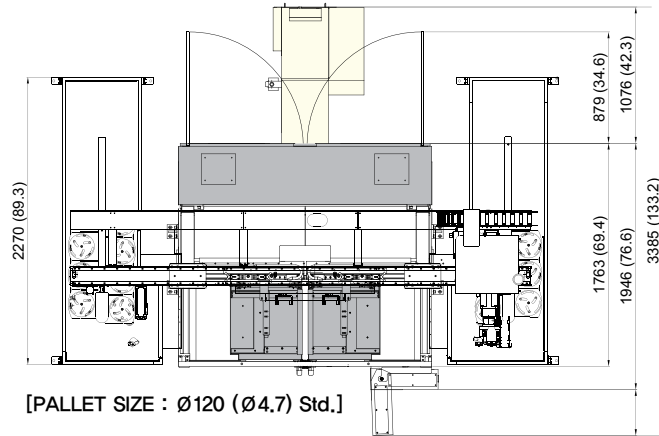

[PALLET SIZE : Ø120 (Ø4.7) Std.]

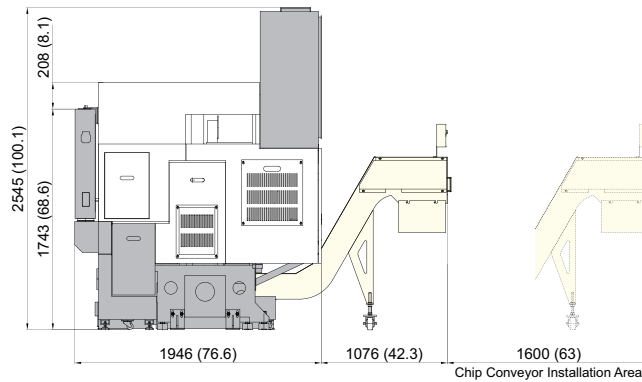
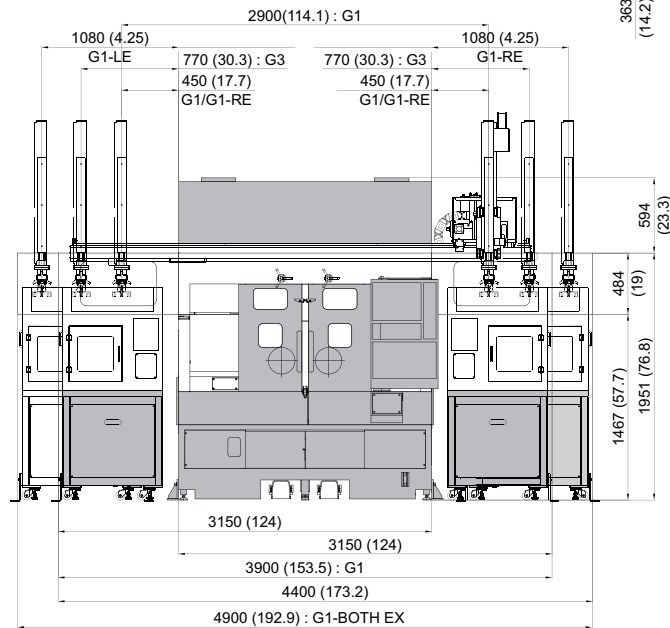

# SPECIFICATIONS

## External Dimensions

unit : mm(in)

### LF2600 II Series

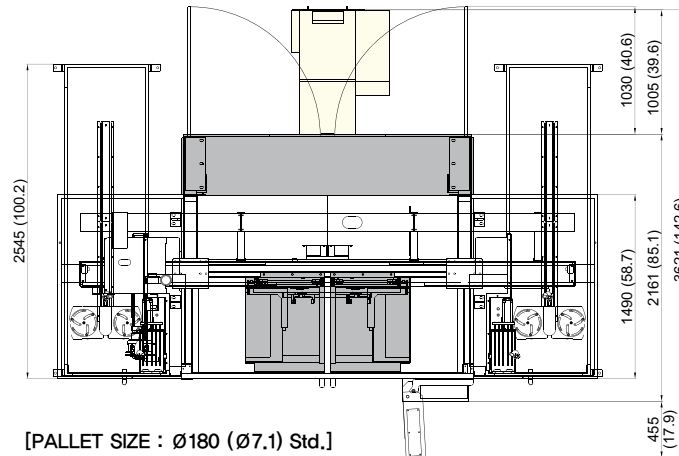

[PALLET SIZE : Ø180 (Ø7.1) Std.]

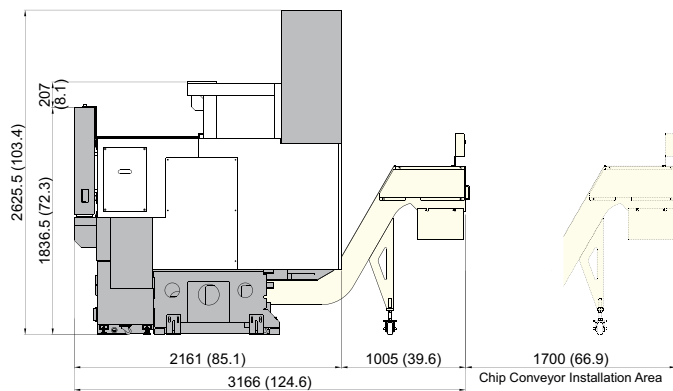
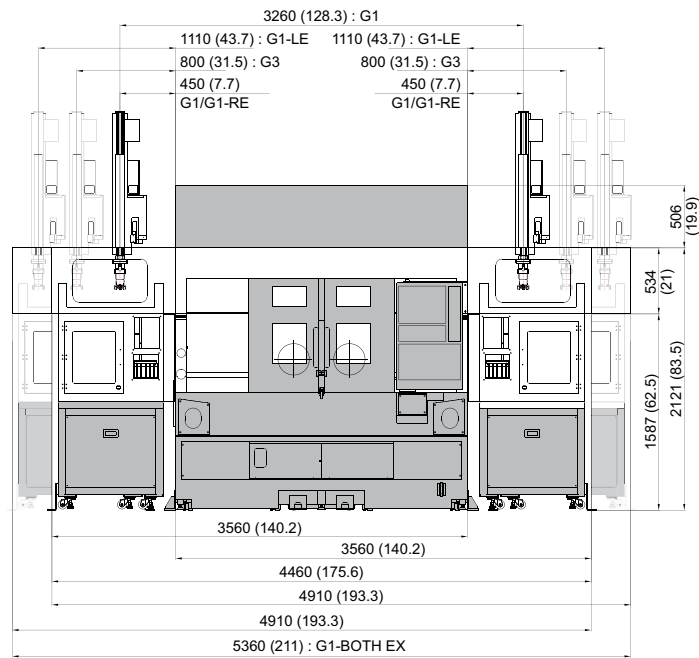

# SPECIFICATIONS

## Interference

unit : mm(in)

### LF2200 II Series

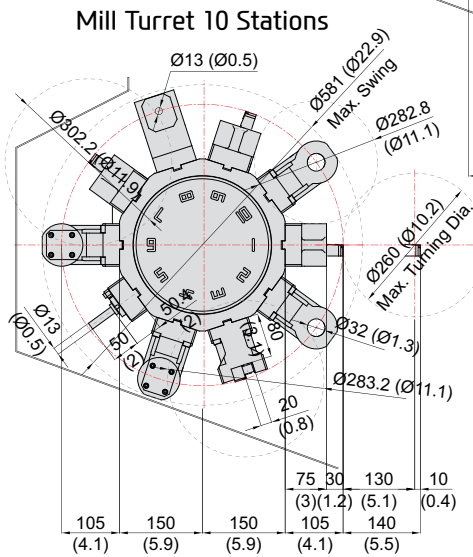
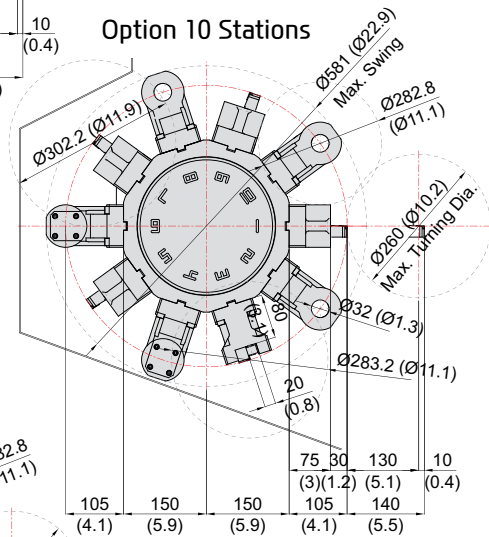
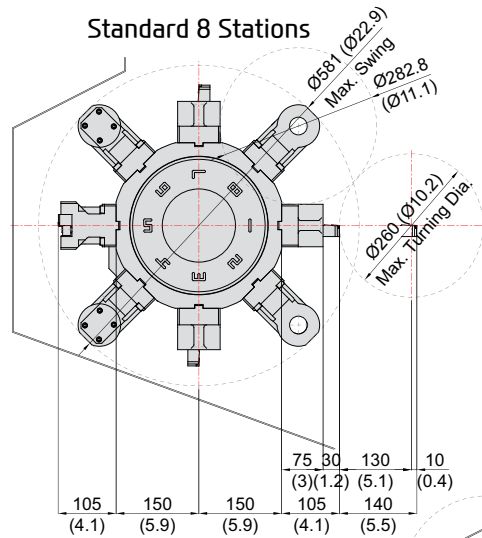

# SPECIFICATIONS

Interference

unit : mm(in)

## LF2600 II Series

Standard 10 Stations

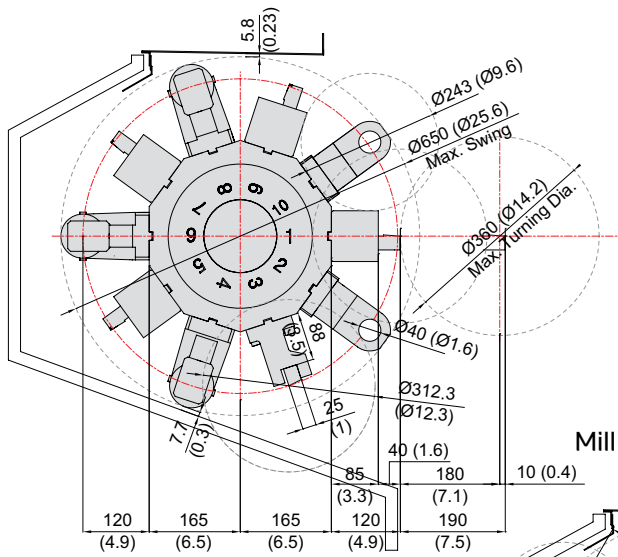

Mill Turret 12 Stations

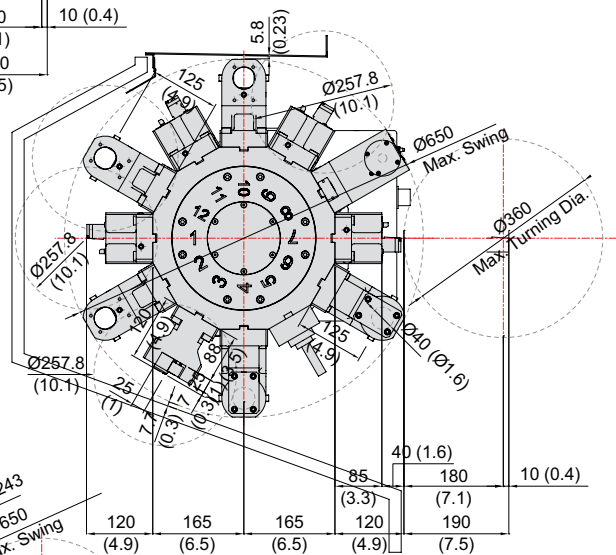

Mill Turret 10 Stations

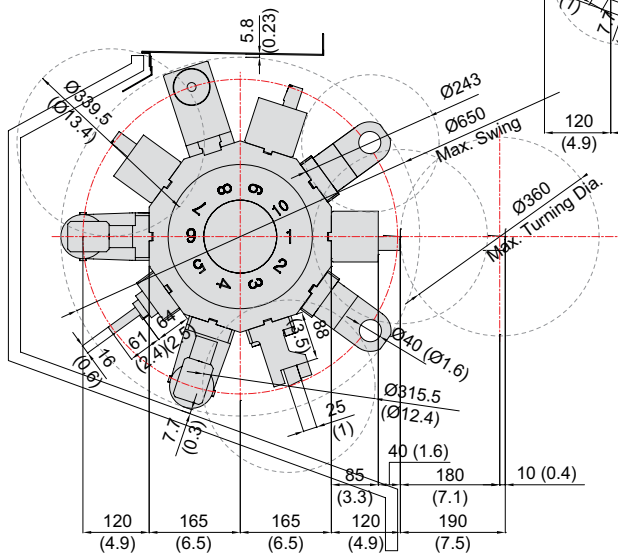



# SPECIFICATIONS

## Tooling System

unit : mm(in)

### LF2200 II Series

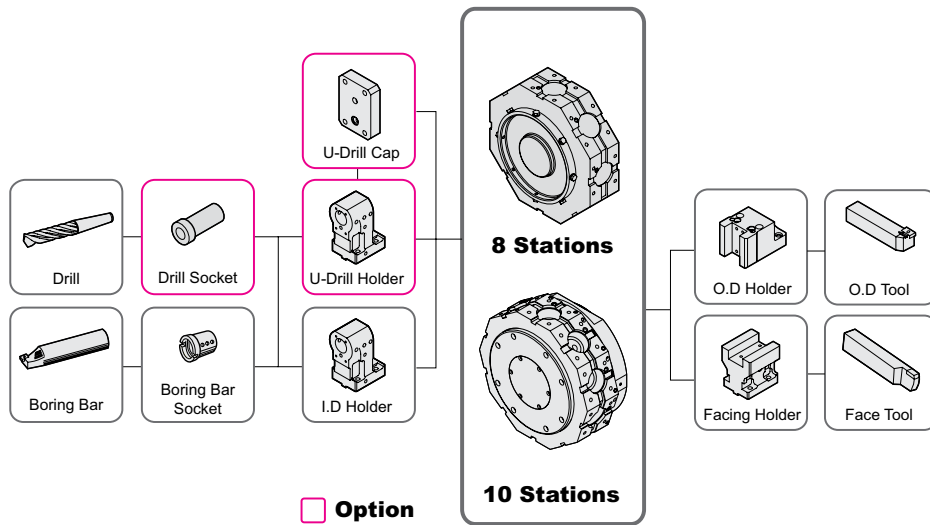

### Tooling Parts Detail

ITEM			8 Stations		10 Stations		
			mm Unit	inch Unit	mm Unit	inch Unit	
Turning Holder	O.D Holder	Right/Left	6	6	8	8	
	Facing Holder		2	2	2	2	
Boring Holder	I.D Holder	Std.	4	4	6	6	
	U-Drill Holder		4	4	4	4	
Driven Holder	Straight Mill Holder	Std.	-	-	-	-	
	Angular Mill Holder	Std.	-	-	-	-	
Socket	Boring	Ø8 (Ø5/16")	2	2	2	2	
		Ø10 (Ø3/8")	2	2	2	2	
		Ø12 (Ø1/2")	2	2	2	2	
		Ø16 (Ø5/8")	2	2	2	2	
		Ø20 (Ø3/4")	2	2	2	2	
		Ø25 (Ø1")	2	2	2	2	
	Drill	MT 2		-	-	-	-
		MT 1 × MT 2		-	-	-	-
	ER Collet		-	-	-	-	

Specifications are subject to change without notice for improvement.

# SPECIFICATIONS

## Tooling System

unit : mm(in)

### LF2200M II Series

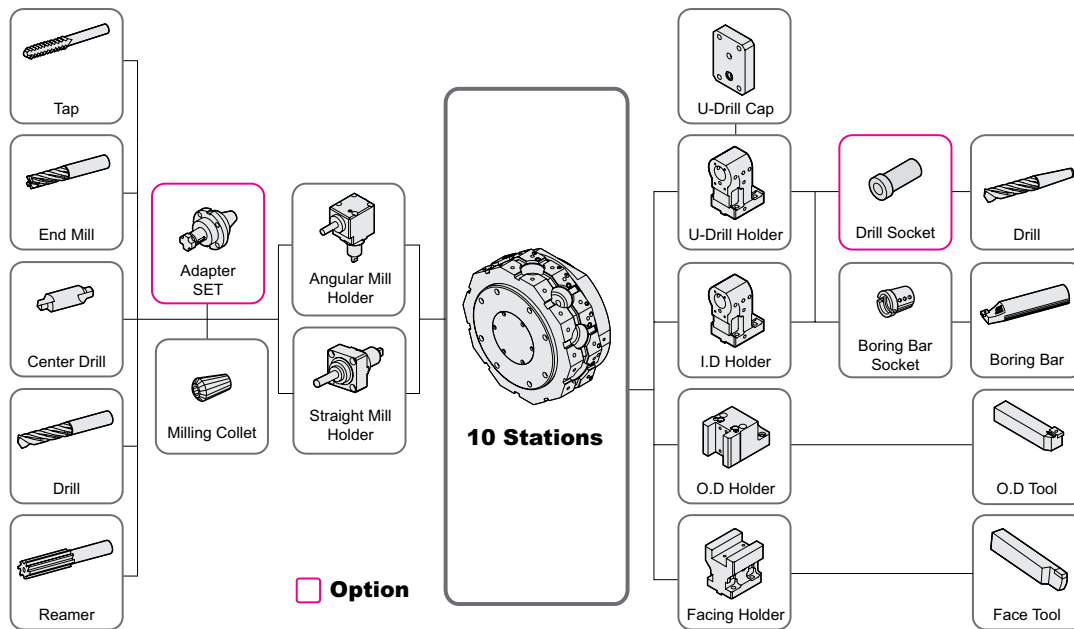

### Tooling Parts Detail

ITEM	10 Stations			
	mm Unit	inch Unit		
Turning Holder	O.D Holder	Right/Left	6	6
	Facing Holder		2	2
Boring Holder	I.D Holder	Std.	4	4
	U-Drill Holder		4	4
Driven Holder	Straight Mill Holder	Std.	2	2
	Angular Mill Holder	Std.	2	2
Socket	Boring	Ø8 (Ø5/16")	2	2
		Ø10 (Ø3/8")	2	2
		Ø12 (Ø1/2")	2	2
		Ø16 (Ø5/8")	2	2
		Ø20 (Ø3/4")	2	2
		Ø25 (Ø1")	2	2
	Drill	MT 2	-	-
		MT 1 × MT 2	-	-
ER Collet		2 set	2 set	

# SPECIFICATIONS

## Tooling System

unit : mm(in)

### LF2600 II Series

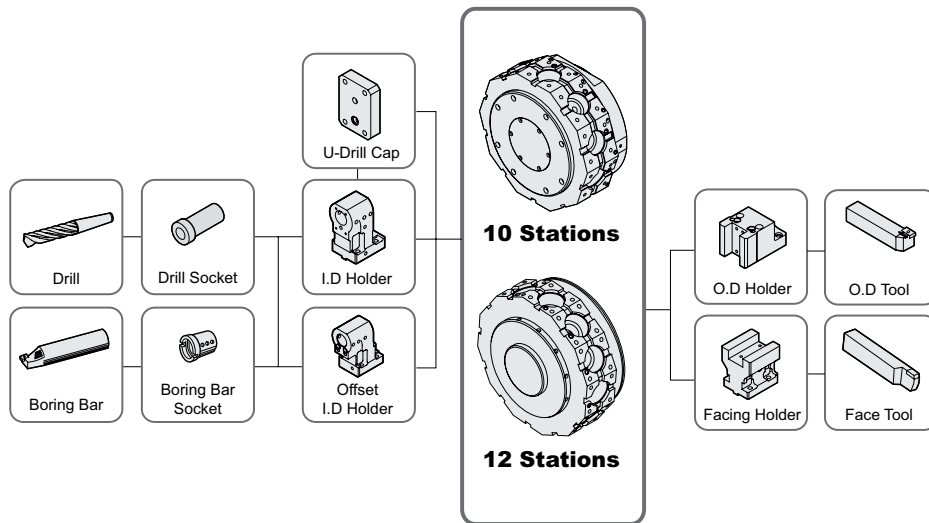

### Tooling Parts Detail

ITEM			10 Stations		12 Stations	
			mm Unit	inch Unit	mm Unit	inch Unit
Turning Holder	O.D Holder	Right/Left	8	8	10	10
	Facing Holder		2	2	2	2
Boring Holder	I.D Holder	Std.	4	4	4	4
		Offset	6	6	8	8
Driven Holder	Straight Mill Holder	Std.	-	-	-	-
	Angular Mill Holder	Std.	-	-	-	-
Socket	Boring	Ø10 (Ø3/8")	2	2	2	2
		Ø12 (Ø1/2")	2	2	2	2
		Ø16 (Ø5/8")	2	2	2	2
		Ø20 (Ø3/4")	2	2	2	2
		Ø25 (Ø1")	2	2	2	2
		Ø32 (Ø1 1/4")	2	2	2	2
	Drill	MT 2	2	2	2	2
		MT 1 × MT 2	2	2	2	2
	ER Collet		-	-	-	-

Specifications are subject to change without notice for improvement.

# SPECIFICATIONS

## Tooling System

unit : mm(in)

### LF2600M II Series

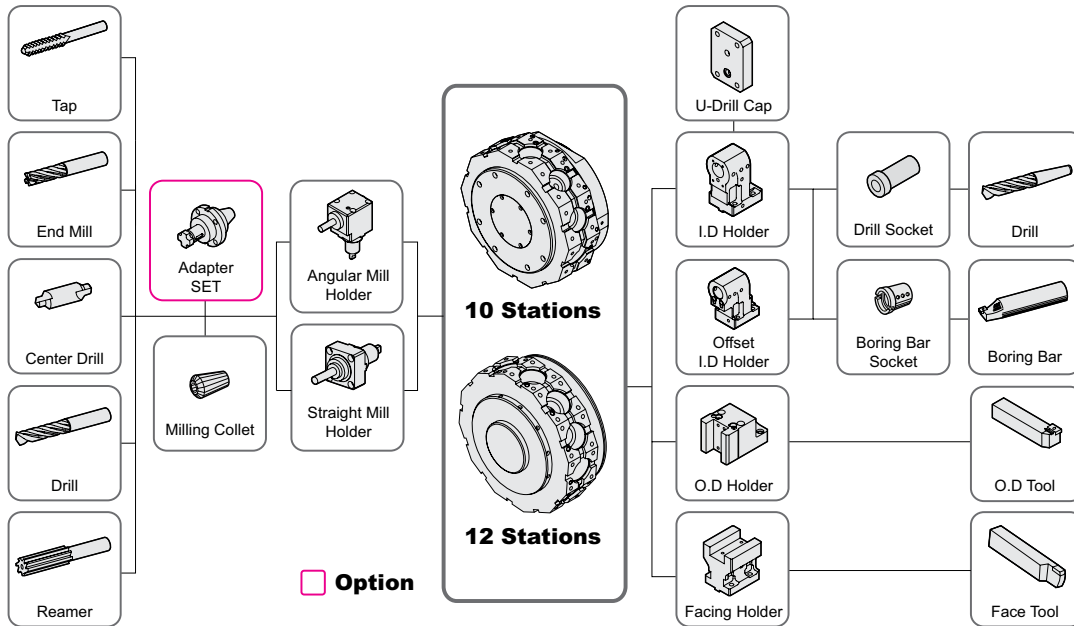

### Tooling Parts Detail

ITEM			10 Stations		12 Stations	
			mm Unit	inch Unit	mm Unit	inch Unit
Turning Holder	O.D Holder	Right/Left	6	6	8	8
	Facing Holder		2	2	2	2
Boring Holder	I.D Holder	Std.	4	4	4	4
		Offset	4	4	6	6
Driven Holder	Straight Mill Holder	Std.	2	2	2	2
	Angular Mill Holder	Std.	2	2	2	2
Socket	Boring	Ø10 (Ø3/8")	2	2	2	2
		Ø12 (Ø1/2")	2	2	2	2
		Ø16 (Ø5/8")	2	2	2	2
		Ø20 (Ø3/4")	2	2	2	2
		Ø25 (Ø1")	2	2	2	2
		Ø32 (Ø1 1/4")	2	2	2	2
	Drill	MT 2	2	2	2	2
		MT 1 × MT 2	2	2	2	2
ER Collet		2 set	2 set	2 set	2 set	

# SPECIFICATIONS

## Tooling Travel Range

unit : mm(in)

### LF2200 II Series

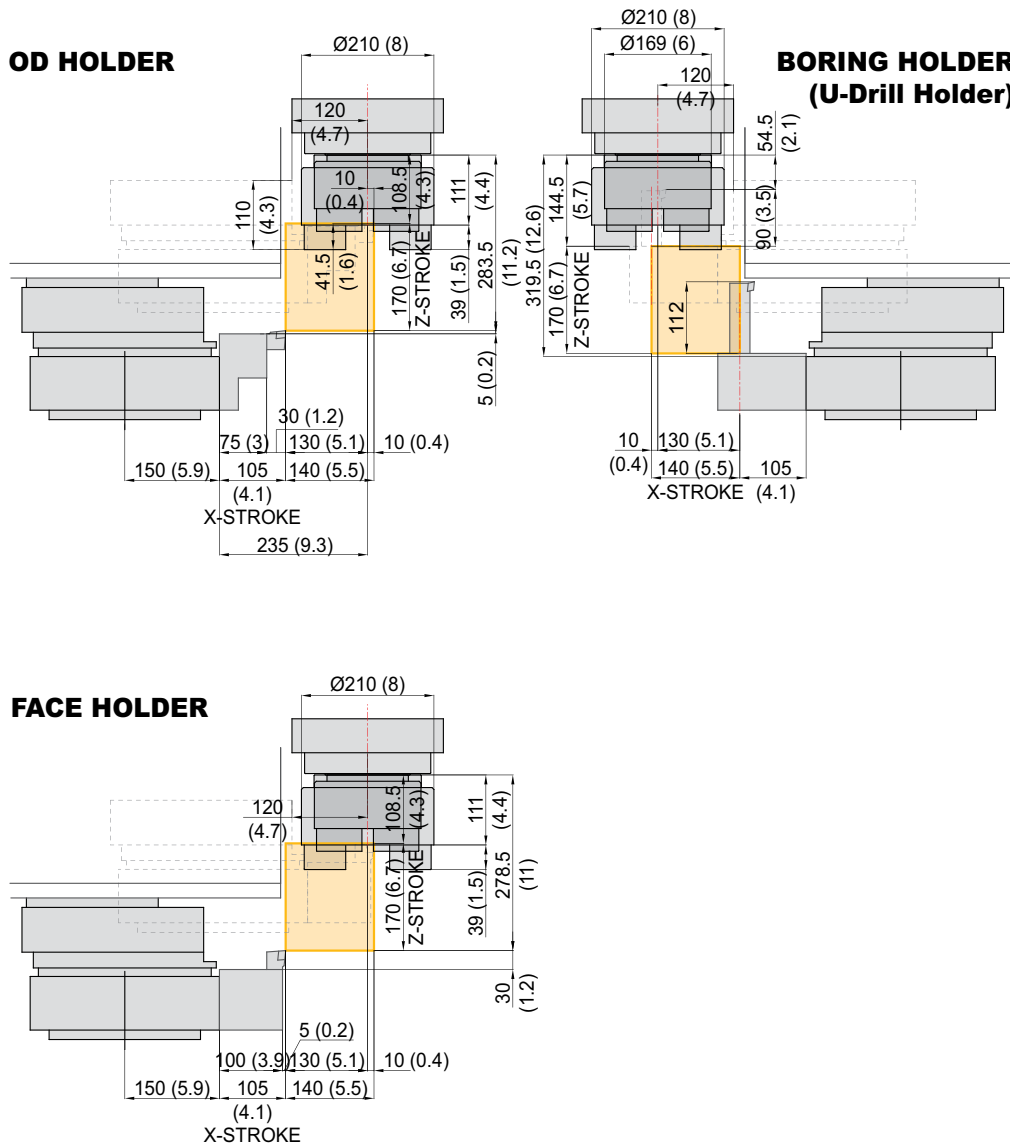

# SPECIFICATIONS

Tooling Travel Range

unit : mm(in)

LF2200M II Series

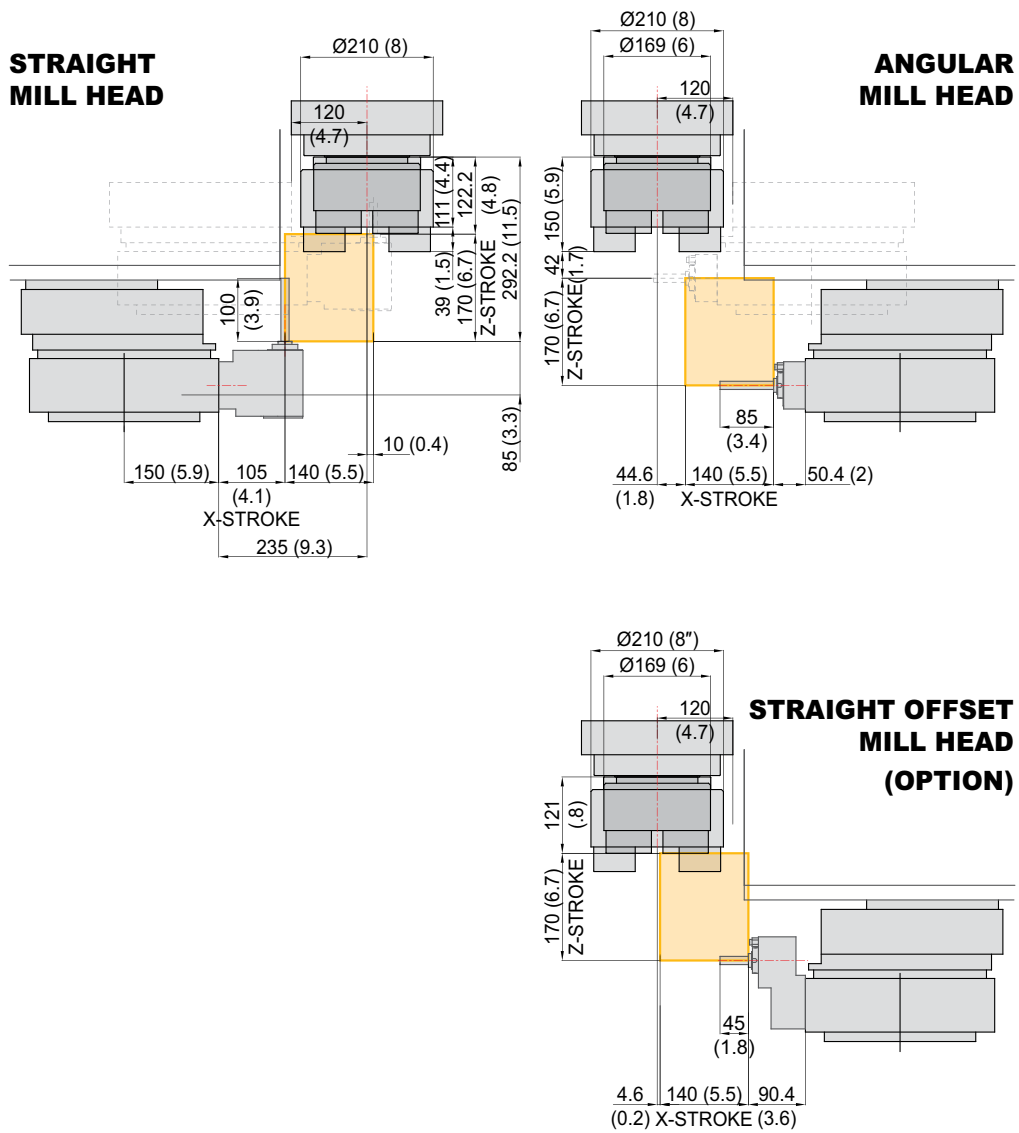

# SPECIFICATIONS

Tooling Travel Range

unit : mm(in)

LF2600 II Series

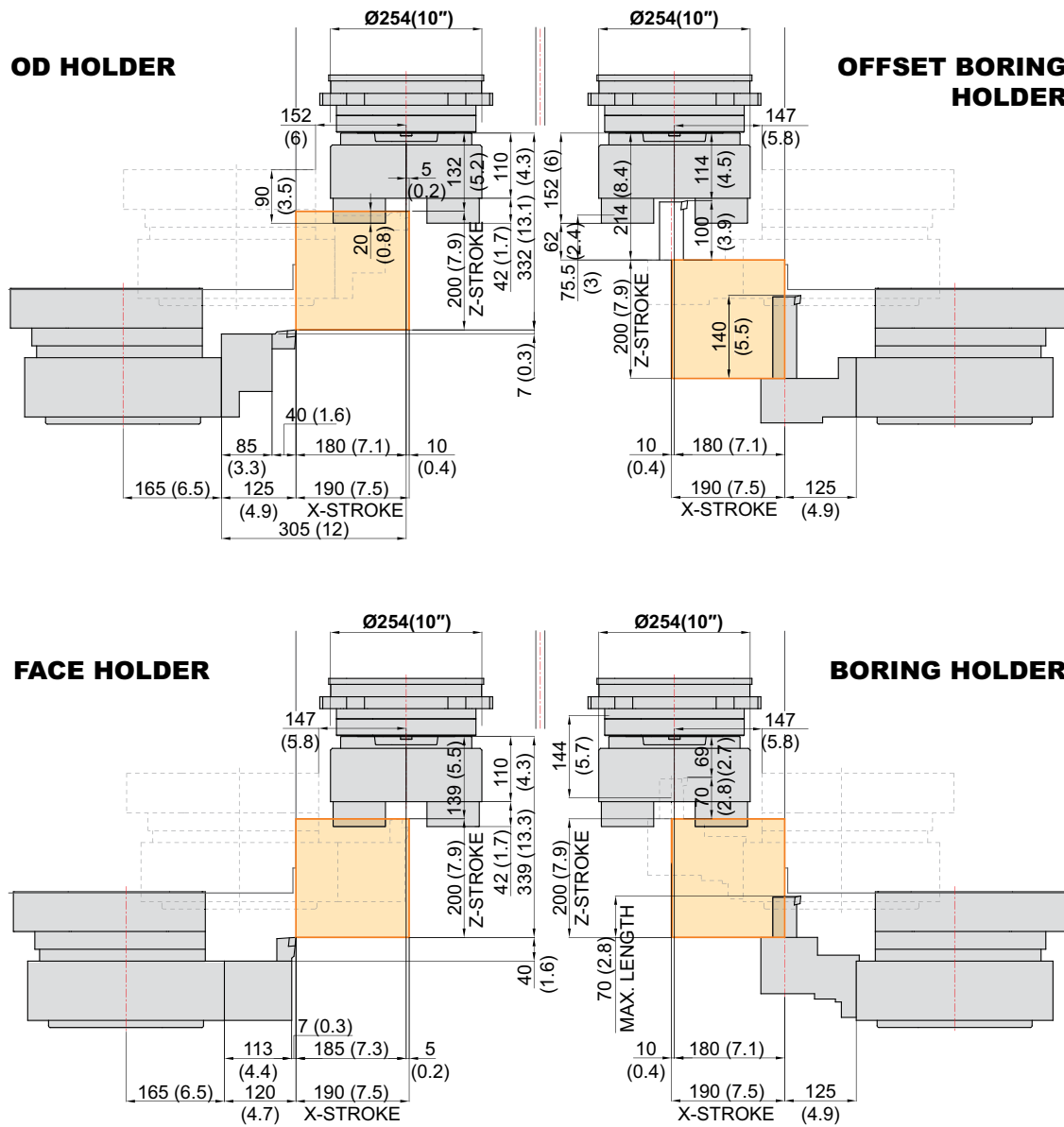

# SPECIFICATIONS

Tooling Travel Range

unit : mm(in)

LF2600M II Series

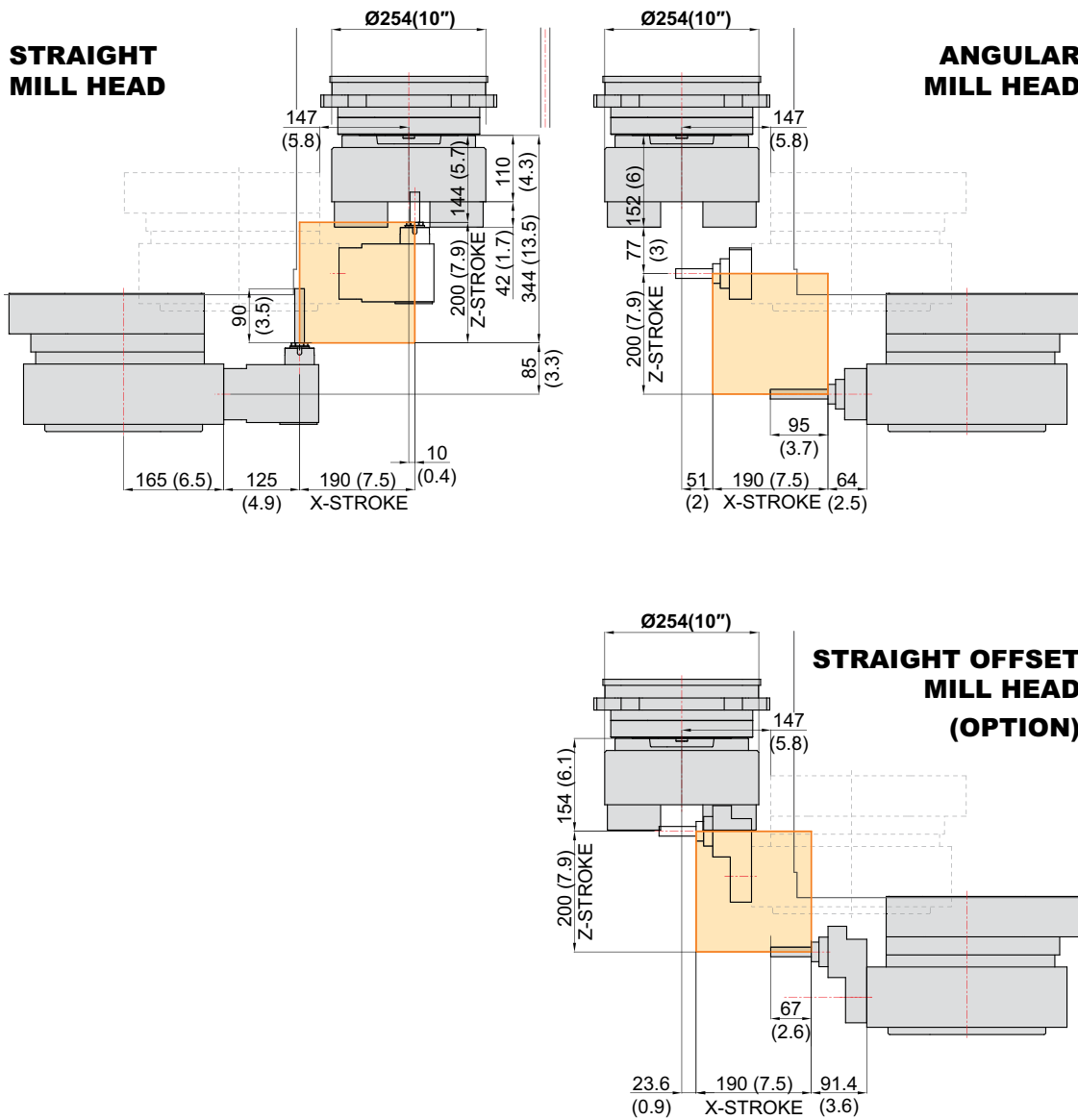



# SPECIFICATIONS

## Specifications

[ ] : Option

ITEM		LF2200 II	LF2200Quick II	LF2200M II	LF2200MQuick II	
CAPACITY	Z-axis Slide Cover Swing	mm(in)	Ø276			
	Max. Turning Dia.	mm(in)	Ø260			
	Max. Turning Length	mm(in)	170			
	Bar Capacity	mm(in)	Ø45			
SPINDLE	Chuck Size	inch	[Option : 6" / 8"]			
	Spindle Bore	mm(in)	Ø46			
	Distance Between the Spindle	mm(in)	370			
	Spindle Speed (rpm)	r/min	[6" : 6,000 / 8" : 4,500]			
	Motor (Max/Cont.)	kW(HP)	[15/11 (20/15)]			
	Torque (Max/Cont.)	N·m(lbf·ft)	[127/70 (93.7/51.6)]			
	Spindle Type	-	BELT			
	Spindle Nose	-	A2-5			
C-axis Indexing	deg	-	0.001°			
FEED	Travel (X/Z)	mm(in)	140/170 (5.5/6.7)			
	Rapid Traverse Rate (X/Z)	m/min(ipm)	24/24 (945/945)	24/36 (945/1,417)	24/24 (945/945)	24/36 (945/1,417)
	Slide Type	-	BOX GUIDE	ROLLER LM GUIDE	BOX GUIDE	ROLLER LM GUIDE
TURRET	No. of Tools	ea	8 [10]		10	
	Tool Size	O.D	mm(in)	□ 20 (□ 3/4")		
		I.D	mm(in)	Ø32 (Ø1 1/4")		
	Indexing Time	sec	0.10			
LIVE TOOL	Motor (Max/Cont.)	kW(HP)	-	2.75/1.85 (3.7/2.5)		
	Milling Tool Speed (rpm)	r/min	-	6,000		
	Torque (Max/Cont.)	N·m(lbf·ft)	-	26.2/11.9 (19.3/8.8)		
	Collet Size	mm(in)	-	Ø13 (ER20)		
	Type	-	-	BMT45		
TANK CAPACITY	Coolant Tank	ℓ (gal)	160 (42.3)			
	Lubricating Tank	ℓ (gal)	4 (1.1)			
POWER SUPPLY	Electric Power Supply	kVA	40			
	Thickness of Power Cable	mm <sup>2</sup>	Over 50			
	Voltage	V/Hz	220/60 (200/50*)			
MACHINE	Floor Space (L×W)	mm(in)	2,000×1,946 (78.7×76.6) [G1 Type : 3,900×1,946 (153.5×76.6)]			
	Height	mm(in)	2,545 (100.2) [G1 Type : 3,070 (20.9)]			
	Weight	kg(lb)	5,200 (11,464)			
PC	Controller	-	HYUNDAI WIA FANUC i Series – Smart Plus			

\*) Using 50Hz voltage instead of 60Hz may lower the output of motors. (excluding servo motors and inverter motors)  
Specifications are subject to change without notice for improvement.

# SPECIFICATIONS

## Specifications

[ ] : Option ● : High-Torque

ITEM		LF2600 II	LF2600Quick II	LF2600M II	LF2600MQuick II	
CAPACITY	Z-axis Slide Cover Swing	mm(in)	Ø370 (Ø14.6")			
	Max. Turning Dia.	mm(in)	Ø360 (Ø14.2")			
	Max. Turning Length	mm(in)	200 (7.9")			
	Bar Capacity	mm(in)	Ø65 (Ø2.6")			
SPINDLE	Chuck Size	inch	[Option : 8" / 10"]			
	Spindle Bore	mm(in)	Ø75 (Ø3")			
	Distance Between the Spindle	mm(in)	450 (17.7")			
	Spindle Speed (rpm)	r/min	[8" : 4,000 / 10" : 3,500]			
	Motor (Max/Cont.)	kW(HP)	[15/11 (20/15)] [High-Torque : 18.5/15 (25/20)]			
	Torque (Max/Cont.)	N·m(lbf·ft)	[254.5/140 (187.7/103.3)] [High-Torque : 403/245 (297.2/180.7)]			
	Spindle Type	-	BELT			
	Spindle Nose	-	A2-6			
	C-axis Indexing	deg	-	0.001°		
FEED	Travel (X/Z)	mm(in)	190/200 (7.5/7.9)			
	Rapid Traverse Rate (X/Z)	m/min(ipm)	24/24 (945/945)	24/36 (945/1,417)	24/24 (945/945)	24/36 (945/1,417)
	Slide Type	-	BOX GUIDE	ROLLER LM GUIDE	BOX GUIDE	ROLLER LM GUIDE
TURRET	No. of Tools	ea	10 [12]			
	Tool Size	O.D	mm(in)	□25 (1")		
		I.D	mm(in)	Ø40 (Ø1 1/2")		
	Indexing Time	sec	0.10			
LIVE TOOL	Motor (Max/Cont.)	kW(HP)	-	5.5/3.7 (7.4/5)		
	Milling Tool Speed (rpm)	r/min	-	5,000		
	Torque (Max/Cont.)	N·m(lbf·ft)	-	52.5/26 (38.7/19.2)		
	Collet Size	mm(in)	-	Ø16 (ER25)		
	Type	-	-	BMT55		
TANK CAPACITY	Coolant Tank	ℓ (gal)	255 (67.4)			
	Lubricating Tank	ℓ (gal)	4 (1.1)			
POWER SUPPLY	Electric Power Supply	kVA	40			
	Thickness of Power Cable	mm <sup>2</sup>	Over 50			
	Voltage	V/Hz	220/60 (200/50*)			
MACHINE	Floor Space (L×W)	mm(in)	2,360×3,073 (92.9"×121") [G1 Type : 4,360×3,073 (171.7"×121")]			
	Height	mm(in)	2,626 (103.4") [G1 Type : 3,438 (135.4")]			
	Weight	kg(lb)	6,500 (14,330)			
PC	Controller	-	HYUNDAI WIA FANUC – SMART PLUS			

# CONTROLLER

## HYUNDAI WIA FANUC – SMART PLUS

[ ] : Option

Controlled axis / Display / Accuracy Compensation	
Control axes	2 axes (X, Z) / 3 axes (X, Z, C) / 4 axes (X,Z,Y,C) 5 axes (X, Z, B, C, A) / 6 axes (X, Z, Y, B, C, A) 7 axes (X1/Z1, X2/Z2, B2, C1/C2)
Simultaneously controlled axes	2 axes [Max. 4 axes]
Designation of spindle axes	3 axes [Max. 4 axes]
Least setting Unit	X, Z, Y, B axes : 0.001 mm (0.0001 inch) C, A axes : 0.001 deg
Least input increment	X, Z, Y, B axes : 0.001 mm (0.0001 inch) C, A axes : 0.001 deg
Inch / Metric conversion	G20 / G21
High response vector control	
Interlock	All axes / Each axis
Machine lock	All axes
Backlash compensation	± 0~9999 pulses (exc. Rapid traverse / Cutting feed)
Position switch	
LCD / MDI	15 inch LCD unit (with Touch Panel)
Feedback	Absolute motor feedback
Stored stroke check 1	Over travel
Stored stroke check 2, 3	
PMC axis control	
Operation	
Automatic operation (Memory)	
MDI operation	
DNC operation	Needed DNC software / CF card
Program restart	
Wrong operation prevention	
Program check function	Dry run
Single block	
Search function	Program Number / Sequence Number
Interpolation functions	
Nano interpolation	
Positioning	G00
Linear interpolation	G01
Circular interpolation	G02, G03
Exact stop mode	Single : G09, Continuous : G61
Dwell	G04, 0 ~ 9999.9999 sec
Skip	G31
Reference position return	1st reference : G28, 2nd reference : G30 Ref. position check : G27
Thread synchronous cutting	G33
Thread cutting retract	
Variable lead thread cutting	
Multi / Continuous threading	
Feed function / Acc. & Dec. control	
Manual feed	Rapid traverse Jog : 0~2,000 mm/min (79 ipm) Manual handle : x1, x10, x100 pulses Reference position return
Cutting Feed command	Direct input F code
Feedrate override	0 ~ 200% (10% Unit)
Rapid traverse override	1%, F25%, 50%, 100%
Override cancel	
Feed per minute	G98
Feed per revolution	G99
Look-ahead block	1 block
Program input	
Tape Code	EIA / ISO
Optional block skip	9 ea
Program stop / end	M00, M01 / M02, M30
Maximum command unit	± 999,999.999 mm (± 99,999.9999 inch)
Plane selection	X-Y : G17 / Z-X : G18 / Y-Z : G19
Workpiece coordinate system	G52, G53, 6 pairs (G54 ~ G59)
Manual absolute	Fixed ON
Programmable data input	G10
Sub program call	10 folds nested
Custom macro	#100 ~ #199, #500 ~ #999
G code system	A, B/C
Programmable mirror image	G51.1, G50.1
G code preventing buffering	G4.1
Direct drawing dimension program	Including Chamfering / Corner R
Conversational Program	SmartGuide-i

Program input	
Multiple repetitive cycles	I, II
Canned cycle for turning	
Auxiliary function / Spindle speed function	
Auxiliary function	M & 4 digit
Level-up M Code	High speed / Multi / Bypass M code
Spindle speed function	S & 5 digit, Binary output
Spindle override	0% ~ 150% (10% Unit)
Multi position spindle orientation	M19 (S##)
Rigid tapping	
Constant surface speed control	G96, G97
Tool function / Tool compensation	
Tool function	T & 2 digit + Offset 2 digit
Tool life management	
Tool offset pairs	128 pairs
Tool nose radius compensation	G40, G41, G42
Geometry / Wear compensation	
Direct input of offset measured B	
Editing function	
Part program storage size	5,120m (2MB)
No. of registerable programs	1,000 ea
Program protect	
Background editing	
Extended part program editing	Copy, move and change of NC program
Memory card program edit	
Data input / output & Interface	
I/O interface	CF card, USB memory Embedded Ethernet interface
Screen hard copy	
External message	
External key input	
External workpiece number search	
Automatic data backup	
Setting, display and diagnosis	
Self-diagnosis function	
History display & Operation	Alarm & Operator message & Operation
Run hour / Parts count display	
Maintenance information	
Actual cutting feedrate display	
Display of spindle speed / T code	
Graphic display	
Operating monitor screen	Spindle / Servo load etc.
Power consumption monitoring	Spindle & Servo
Spindle / Servo setting screen	
Multi language display	Support 24 languages
Display language switching	Selection of 5 optional Languages
LCD Screen Saver	Screen saver
Unexpected disturbance torque	BST (Back spin torque limit)
Function for machine type	
Cs contour control (C & A axes)	Mill, MS, Y, SY, LF-Mill, TTMS, TTSY
Polar coordinate interpolation	Mill, MS, Y, SY, LF-Mill, TTMS, TTSY
Cylindrical interpolation	Mill, MS, Y, SY, LF-Mill, TTMS, TTSY
Polygon turning (2 Spindles)	Mill, MS, Y, SY, LF-Mill, TTMS, TTSY
Canned cycle for drilling	Mill, MS, Y, SY, LF-Mill, TTMS, TTSY
Spindle orientation expansion	MS, SY, TTS, TTMS, TTSY
Spindle synchronous control	MS, SY, TTS, TTMS, TTSY
Torque control	MS, SY, TTS, TTMS, TTSY
Y axis offset	Y, SY, TTSY
Arbitrary angular control	Y, SY, TTSY
Composite / Superimposed control	MS, SY, TTS, TTMS, TTSY
Balance cutting	TTS, TTMS, TTSY
Option	
Fast ethernet	Needed option board
Data server	Needed option board
Protection of data at 8 levels	
Tool offset pairs	200 pairs
Helical interpolation	
Optional block skip	40 ea, 200 ea (AICC II)

Figures in inch are converted from metric values.

The FANUC controller specifications are subject to change based on the policy of company CNC supplying.

# MOVEMENT FOR BETTER TOMORROW



## ECO FRIENDLY

Protect the environment for all humanity and generation to come

**01**

**Achieve  
carbon  
neutrality**

- Develop Net-zero Roadmap
- Heighten carbon emissions management
- Achieve carbon neutrality goals

**02**

**Boost  
resource  
circulation**

- Detail plans to reduce environmental impact
- Gradually reduce pollutant emissions
- Build eco-friendly supply chain

**03**

**Establish  
environmental  
management  
framework**

- Set up environmental management process
- Assess business impact of climate change risks

## ECO SYSTEM

### MQL (Minimal Quantity Lubrication)

The goal of this system is to spray only the amount of lubricant required to prevent heat and chip build up at the cutting tool or work piece face.

#### Example of Turning Center Application

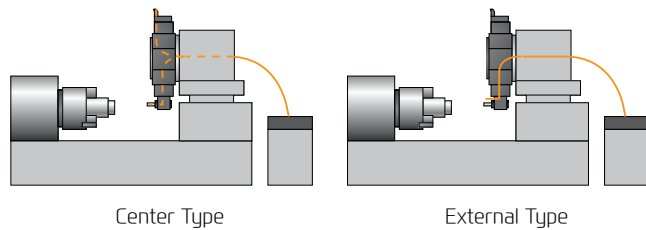

#### Example of Etc.

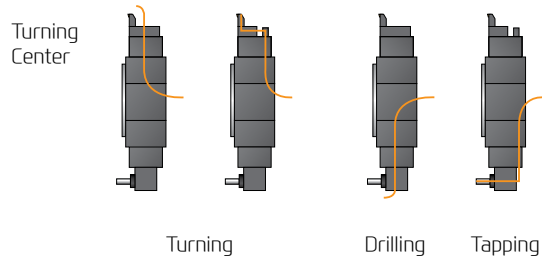

Oil Skimmer

An oil skimmer can increase coolant and tool life by removing tramp oil contaminants.



Mist Collector

Mist Collector reduces the amount of smoke and oil mist in the air. This helps build a safe and comfortable working environment and improve durability.

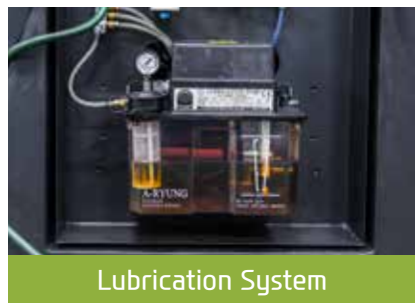

Lubrication System

By applying lubricant only when the machines axis are moving lubrication consumption is reduced by compared to standard systems.

## ENERGY SAVING

### HW-ESS (HYUNDAI WIA Energy Saving System)

HYUNDAI WIA Machine tool provides the optimum power saving function that can easily save energy with an intuitive user interface.



1. **Machine-ready power saving function** : Put all servo motors and other motors into sleep mode when no control or operation is done for a set time
2. **Work light auto-off function** : The work light is turned off automatically when no control or operation is done for a set time
3. **Chip conveyor auto power saving** : Operation/non operation time (timer) can be set to save energy
4. **Auto Power-off** : Auto power off after ending the an operation after a period of time
5. **Eco function** : Machine ready sleep mode can be activated/de-activated from the controller panel
6. **Power consumption monitor** : Real time power consumption can be monitored through the OP screen



YouTube HYUNDAI WIA MT

[www.youtube.com/HYUNDAIWIAMT](http://www.youtube.com/HYUNDAIWIAMT)

## CREATING VALUE IN SEAMLESS MOBILITY

With its top-quality HYUNDAI WIA machine tool creates a new and better world.



<http://machine.hyundai-wia.com>

HYUNDAI WIA Machine Tools  
Global Links

### HEADQUARTER

Changwon Technical Center/R&D Center/Factory 153, Jeongdong-ro, Seongsan-gu, Changwon-si, Gyeongsangnam-do, Korea TEL : +82 55 280 9114 FAX : +82 55 282 9114

Overseas Sales Team /R&D Center 37, Cheoldobangmulgwan-ro, Uiwang-si, Gyeonggi-do, Korea TEL : +82 31 8090 2539

### OVERSEAS OFFICES

HYUNDAI WIA Machine America corp. 450 Commerce Blvd, Carlstadt, NJ 07072, USA TEL : +1-201-987-7298

HYUNDAI WIA Europe GmbH Alexander-Fleming-Ring 57, 65428 Rüsselsheim Germany TEL : +49-0-6142-9256-0

HYUNDAI WIA Machine Tools China 2-3F, Bldg6, No.1535 Hongmei Road, Xuhui District, Shanghai, China TEL : +86-21-6427-9885

Russia Branch Office 141006, Russia, Moscow Region, Mytishchi, Volkovskoe sh. 5A, b. 1, office 306 TEL : +7-495-502-7023

India Branch Office #4/169, 1st Floor, LOTTE BLDG, Rajiv Gandhi Salai, (OMR), Kandanchavadi, Chennai - 600096, Tamilnadu, India TEL : +91-76-0490-3348