

**LV**

**1400/2000**

LV1400 | LV2000MM

HYUNDAI WIA Ram Type Vertical Turning Center

# Technical Leader

The CNC Turning Center LV1400/2000 Series, designed by Hyundai WIA with years of expertise and the latest technology, is designed to maximize productivity for machining large work.

		LV1400	LV2000MM
Max. Swing	mm(in)	Ø1,450 (57.1")	Ø2,040 (80.3")
Max. Turning Dia.	mm(in)	Ø1,400 (55.1")	Ø2,000 (78.7")
Max. Turning Height	mm(in)	850 (33.5")	950 (37.4")/1,700 (66.9")
Table Size	mm(in)	Ø1,000 (39.4")	Ø1,600 (63")
Max. Load Capacity	kg(lb)	4,400 (9,700)	10,000 (22,046)
Spindle Speed	r/min	492	258
Spindle Power	kW(HP)	37/30 (50/40)	37/30 (50/40) [45/37 (60/50)]
Ram Size	mm(in)	200×200 (7.9"×7.9")	240×240 (9.4"×9.4")
Travel (X/Z)	mm(in)	-50~+825 (-2"~+32.5")/800 (31.5")	-250~+1,180 (-9.8~+46.5")/915 (36")

[ ] : Option

# LV

## 1400/2000

Heavy Duty, Large Work Capacity, Vertical Turning Center

- Strengthened heavy duty cutting ability with 2 step gear driven spindle(table)
- Main spindle with cross roller bearings and box guideway for high rigidity
- Rigid table structure for processing heavy loads
- 3 step hydraulic cylinder type crossrail(LV2000MM)
- Various Machining : Turning, tapping, milling, grinding etc.(LV2000MM)
- Linear scale on all axes as standard (LV2000MM)



# 01 BASIC STRUCTURE

Highly Rigid Bed Structure for Heavy Duty Cutting Ram Type Vertical Turning Center

## Ram Head

- Ram Size  
LV1400 : 200×200mm (7.9"×7.9")  
LV2000MM : 240×240mm (9.4"×9.4")
- LV2000MM : 3 Step Crossrail

## ATC

- No. of Tools  
LV1400 : 12 [16] EA  
LV2000MM : 18 EA
- Tool Size (O.D./I.D.)  
LV1400 :  $\varnothing 32/\varnothing 22\text{mm}$  ( $\varnothing 1.3"/0.9"$ )  
LV2000MM :  $\varnothing 32/\varnothing 25\text{mm}$  ( $\varnothing 1.3"/1"$ )

## Spindle & Table

- Spindle Speed  
LV1400 : 492r/min  
LV2000MM : 258r/min
- Table Size  
LV1400 :  $\varnothing 1,000\text{mm}$  ( $\varnothing 39.4"$ )  
LV2000MM :  $\varnothing 1,600\text{mm}$  ( $\varnothing 63"$ )



# STRUCTURE FOR HEAVY CUTTING AND HIGH PRECISION

## HIGH-PRECISION STRUCTURE

### Highly Stable Bed Structure

LV1400/2000 is optimized for heavy duty cutting. Separate Bed Saddle structure made of cast iron minimizes vibration and thermal displacement



### Floor Space (L×W)

LV1400

3,685×3,276 mm

(145.1"×129")

LV2000MM

5,683×3,937 mm

(223.7"×155")

## GUIDEWAY

### Hardened Plate Box Guideway

Highly rigid **hardened plate** attached box guideway increases rigidity and reduces vibration.

Also, **linear scales** on all axes provided as standard enable precise machining. (LV1400 : Option)

Rigidity **10% UP** compared to standard box guideway

### 3 Step Crossrail (LV2000MM)

3 step hydraulic cylinder crossrail(250mm (9.8"×3) enables minimization of vibration and load by extending the length of the ram depending on the machining area. This unique design allows high performance in heavy duty operations.

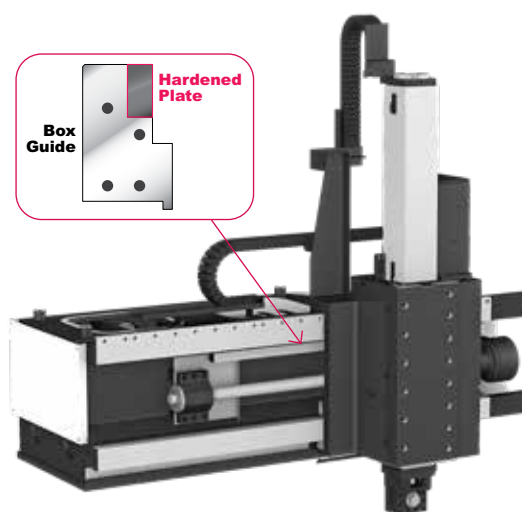
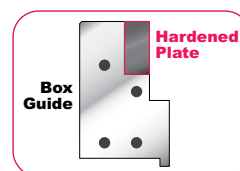

### Travel (X/Z)

LV1400

-50~+825/800 mm

(-2"~+32.5"/31.5")

LV2000MM

-250~+1,180/915 mm

(-9.8~+46.5"/36")

LV1400/2000

# 02 HEAVY DUTY CUTTING

Heavy Duty, Large Work Capacity, Ram Type Vertical Turning Center

## HIGHLY RIGID TABLE

The maximum working height of **1,700mm** (66.9") - LV2000MM enables various workpiece machining.

### Table Size

LV1400

Ø1,000 mm (39.4")

LV2000MM

Ø1,600 mm (63")

### Max. Turning Height

LV1400

850 mm (33.5")

LV2000MM

1,700 mm (66.9")



# HEAVY DUTY CUTTING & HIGH ACCURACY

## SPINDLE

### Spindle for Heavy Cutting

A highly rigid cross roller bearing structure is utilized for heavy duty operations as it minimizes vibration and thermal displacement.

LV2000MM includes C-axis control with ring gear and ring sensor which is superior in noise control and precision indexing than other gear box applied machines.

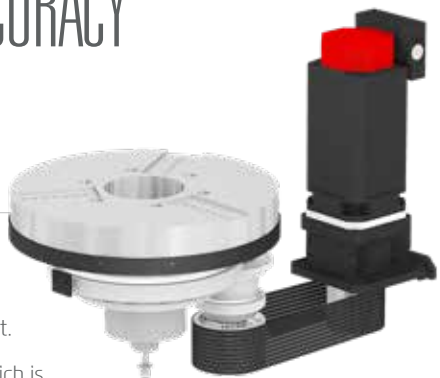

### 2 Step Gear Driven Table

2 step gear driven table provides excellent performance in all speed ranges, especially in low speed.

## RAM HEAD



Various types of machining are possible with ram head: milling with rotary tool, turning, tapping, drilling, grinding and etc.

### Improved Machining Capacity : Tapping **40% UP**

- ⦿ Live Tool Speed : **2,400** rpm
- ⦿ Max. Torque : **769** N·m (567.2 lbf·ft)

## ATC MAGAZINE

ATC is driven by a servo motor which provides faster tool change time and easier maintenance.

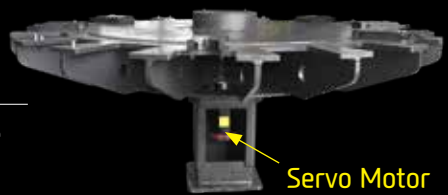

### Number of Tools

**LV1400**  
 Std. : **12EA** (Turning **12**)  
 Opt. : **16 EA** (Turning **16**)

**LV2000MM**  
 Std. : **18EA** (Turning **10** + Milling **7** + Dummy **1**)

# SPECIFICATIONS

## External Dimensions

unit : mm(in)

### LV1400

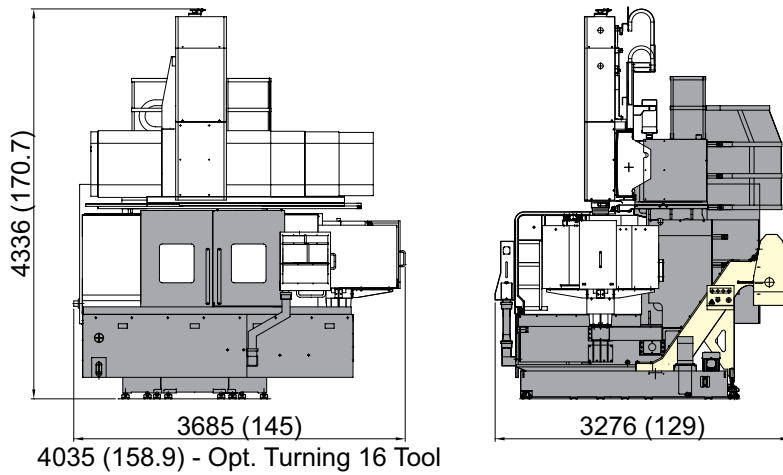

### LV2000MM

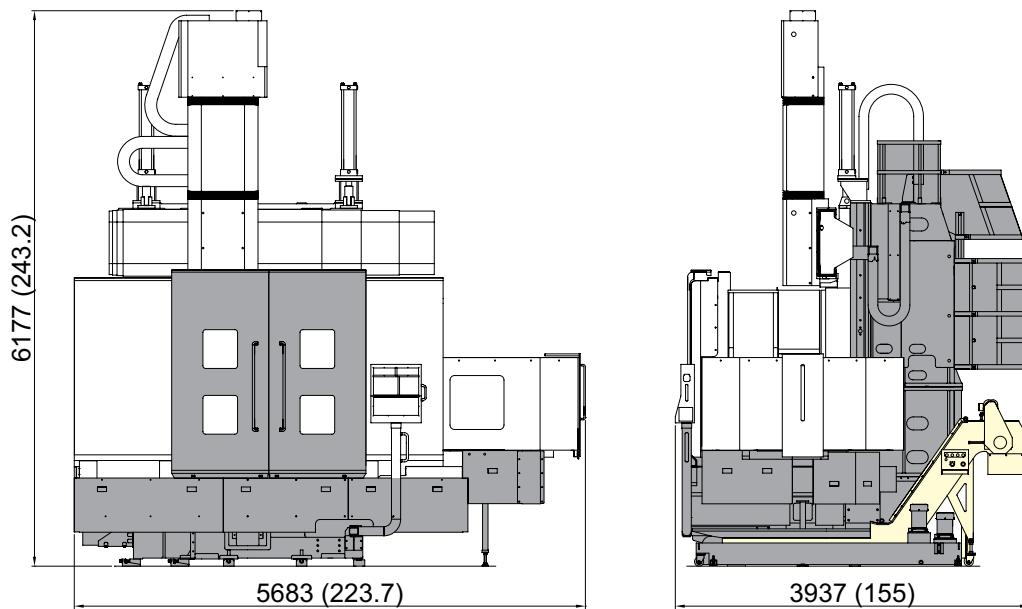



# SPECIFICATIONS

## Tooling System

unit : mm(in)

### LV1400

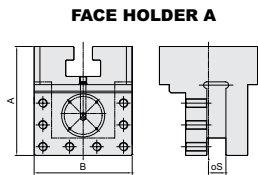

Model	A	B	S	
1084-40-203	200 (7.9)	180 (7.1)	32 (1.3)	STD.

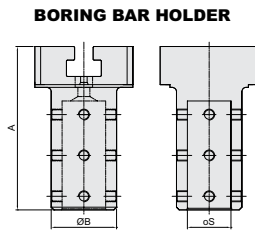

Model	A	B	S	
1084-40-204	300 (11.8)	120 (4.7)	80 (3.1)	STD.

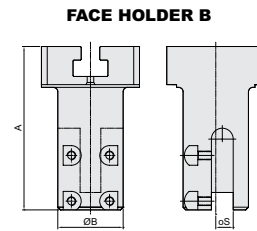

Model	A	B	S	
1084-40-205	300 (11.8)	120 (4.7)	32 (1.3)	STD.

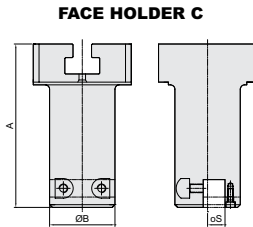

Model	A	B	S	
1084-40-206	300 (11.8)	120 (4.7)	32 (1.3)	STD.

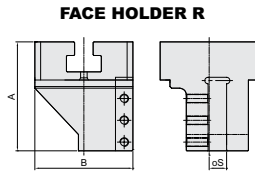

Model	A	B	S	
1084-40-210	200 (7.9)	180 (7.1)	32 (1.3)	OPT.

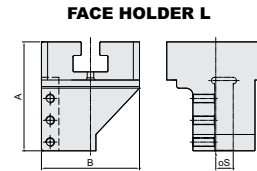

Model	A	B	S	
1084-40-211	200 (7.9)	180 (7.1)	32 (1.3)	OPT.

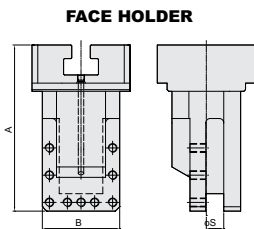

Model	A	B	S	
1084-40-212	305 (12)	142 (5.6)	32 (1.3)	OPT.

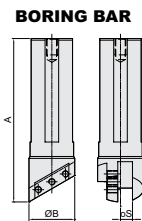

Model	A	B	S	
1084-40-207	300 (11.8)	84 (3.3)	22 (0.9)	STD.
1084-40-213	200 (7.9)	84 (3.3)	22 (0.9)	OPT.

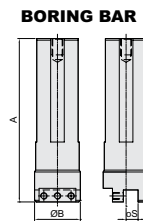

Model	A	B	S	
1084-40-208	300 (11.8)	84 (3.3)	22 (0.9)	STD.
1084-40-214	400 (15.7)	84 (3.3)	22 (0.9)	OPT.

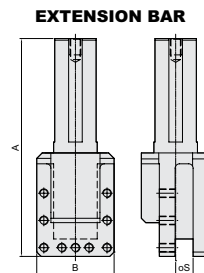

Model	A	B	S	
1084-40-209	400 (15.7)	142 (5.6)	32 (1.3)	OPT.

# SPECIFICATIONS

Tooling System

unit : mm(in)

LV2000MM

### FACE HOLDER-A

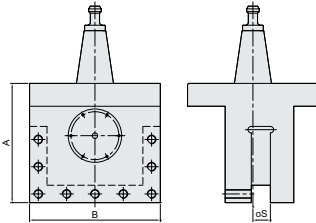

Model	A	B	S	
1085-40-201	219 (8.6)	240 (9.4)	32 (1.3)	STD.

### BORING BAR HOLDER

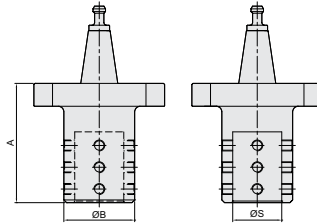

Model	A	B	S	
1085-40-204	219 (8.6)	130 (5.1)	90 (3.5)	STD.

### FACE HOLDER-B

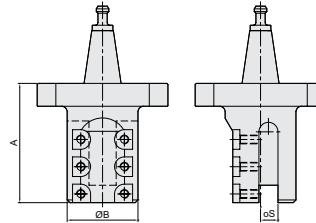

Model	A	B	S	
1085-40-202	219 (8.6)	130 (5.1)	32 (1.3)	OPT.

### FACE HOLDER-C

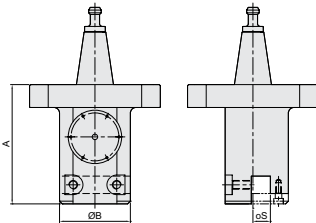

Model	A	B	S	
1085-40-203	219 (8.6)	130 (5.1)	32 (1.3)	OPT.

### FACE HOLDER-R

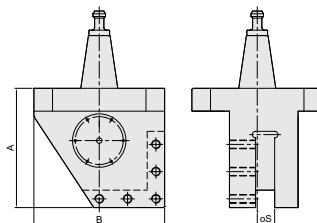

Model	A	B	S	
1085-40-206	219 (8.6)	240 (9.4)	32 (1.3)	OPT.

### FACE HOLDER-L

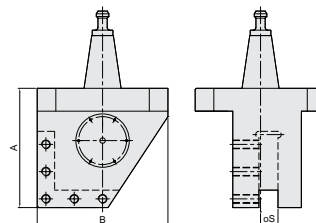

Model	A	B	S	
1085-40-205	219 (8.6)	240 (9.4)	32 (1.3)	OPT.

### CONNECTION HOLDER

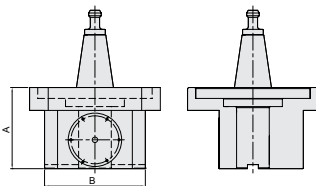

Model	A	B	S	
1085-40-209	149 (5.9)	185 (7.3)	-	OPT.

### EXTENSION HOLDER

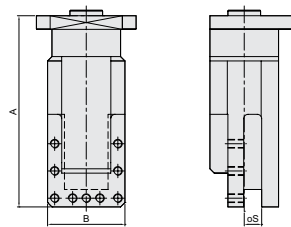

Model	A	B	S	
1085-40-208	351 (13.8)	142 (5.6)	32 (1.3)	OPT.

### BORING BAR

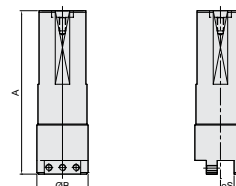

Model	A	B	S	
1085-40-305	300 (11.8)	94 (3.7)	25 (1)	STD.
1085-40-307	400 (15.7)	94 (3.7)	25 (1)	OPT.

### BORING BAR

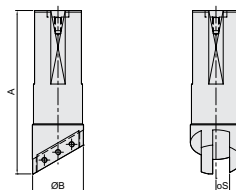

Model	A	B	S	
1085-40-306	300 (11.8)	94 (3.7)	25 (1)	STD.
1085-40-308	400 (15.7)	94 (3.7)	25 (1)	OPT.

### EXTENSION BAR

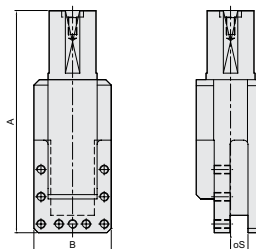

Model	A	B	S	
1085-40-207	408 (16.1)	142 (5.6)	32 (1.3)	OPT.

# SPECIFICATIONS

Tooling System

unit : mm(in)

LV2000MM



## Grinding Head

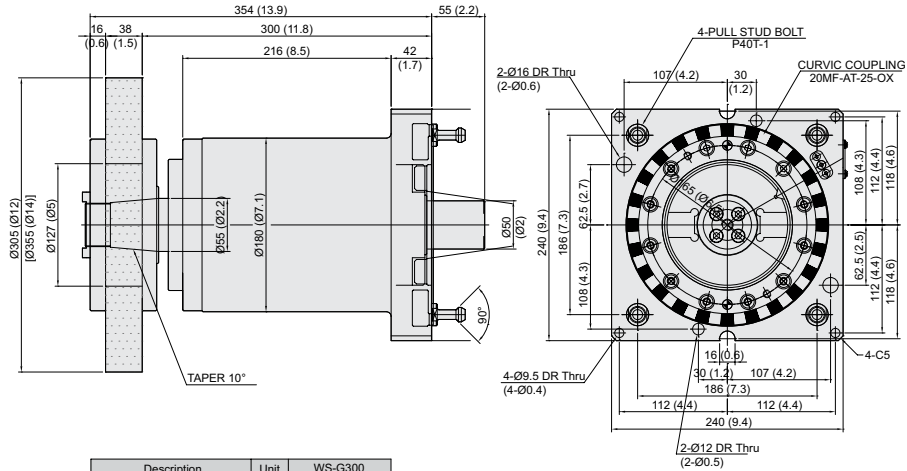

Description	Unit	WS-G300
Length	mm(in)	300 (11.8)
Max. Permissible Speed	rpm	1800
Speed Ratio(In-Out)	-	1 : 1
Lubrication	-	Grease

## Angle Head

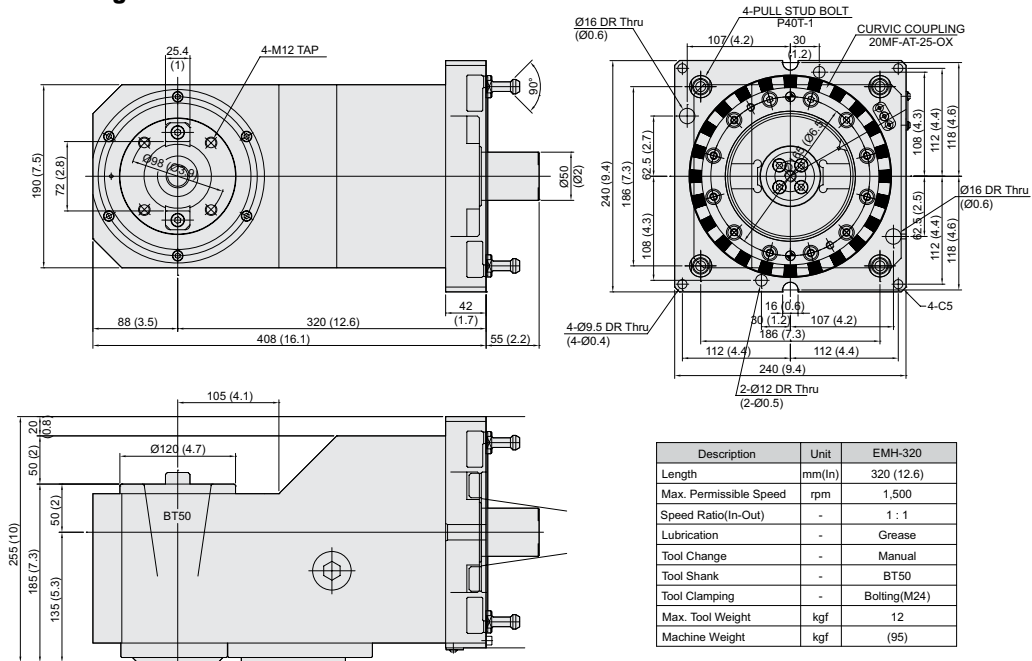

Description	Unit	EMH-320
Length	mm(in)	320 (12.6)
Max. Permissible Speed	rpm	1,500
Speed Ratio(In-Out)	-	1 : 1
Lubrication	-	Grease
Tool Change	-	Manual
Tool Shank	-	BT50
Tool Clamping	-	Bolting(M24)
Max. Tool Weight	kgf	12
Machine Weight	kgf	(95)

◆ These attachments are only applicable in mm unit.

# SPECIFICATIONS

## Tooling Travel Range

unit : mm(in)

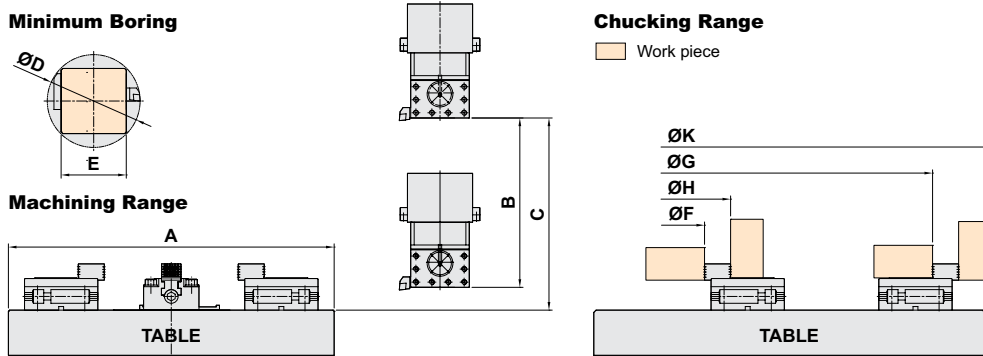

Model	A	B	C	D	E	F	G	H	K	
LV1400	1000 (39.4)	800 (31.5)	850 (33.5)	285 (11.2)	200 (7.9)	319 (12.6)	*	*	1052 (41.4)	Hydraulic Chuck (STD.)
	1000 (39.4)	800 (31.5)	850 (33.5)	285 (11.2)	200 (7.9)	220 (8.7)	890 (35)	360 (14.2)	1000 (39.4)	Independent Chuck (OPT.)
LV2000MM	1600 (63)	915 (36)	MAX.1700 (MAX.67) MIN.950 (MIN.37.4)	335 (13.2)	240 (9.4)	291 (11.5)	1501 (59.1)	451 (17.8)	1661 (65.4)	Independent Chuck (STD.)

\* : The shape of soft jaw changes chucking area.

## Spindle Output/Torque Diagram

**LV1400 492rpm**

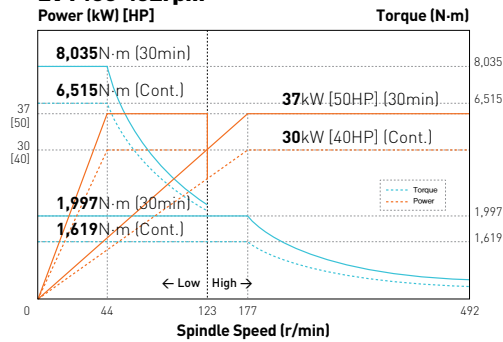

**LV2000MM 258rpm**

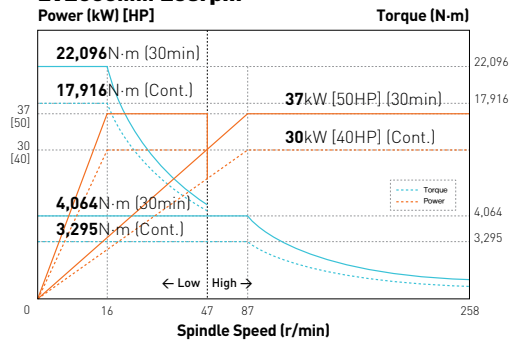

**LV2000MM 258rpm**

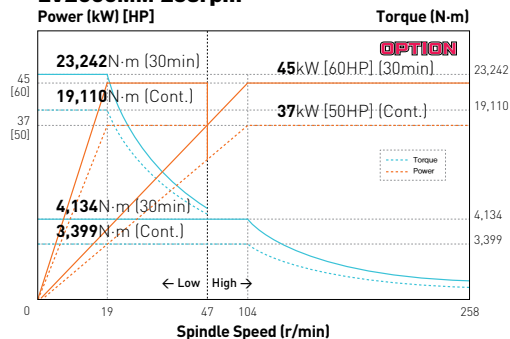

**LV2000MM 2,400rpm (Mill Head)**

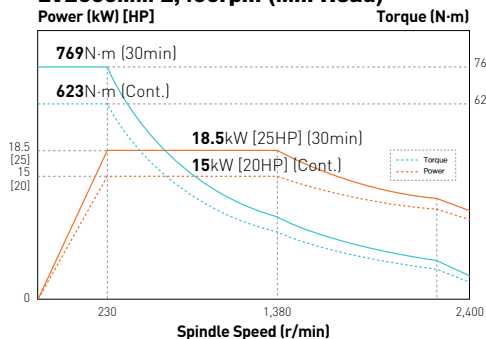

# SPECIFICATIONS

## Specifications

[ ] : Option

ITEM			LV1400	LV2000MM
CAPACITY	Max. Swing	mm(in)	Ø1,450 (Ø57.1")	Ø2,040 (Ø80.3")
	Max. Turning Dia.	mm(in)	Ø1,400 (Ø55.1")	Ø2,000 (Ø78.7")
	Max. Turning Height	mm(in)	850 (33.5")	1,700 (66.9")
	Max. Load Capacity	Kg(lb)	4,400 (9,700)	10,000 (22,046)
FEED	X-Axis	mm(in)	-50 ~ +825 (-2"~+32.5")	-250 ~ +1,180 (-9.8"~+46.5")
	Z-Axis	mm(in)	800 (31.5")	915 (36")
	C-Axis	deg	-	360
	W-Axis	mm(in)	-	250 (9.8")×3 Steps
RAPID TRAVERSE RATE	X/Z-Axis	m/min(ipm)	12/12 (472/472)	
	C-Axis	deg/min	-	750
RAM HEAD	Ram Size	mm(in)	200 (7.9")	Turning 240 (9.4") (Milling BT50)
	Live Tool Speed	r/min	-	2,400
	Live Tool Power (Max./Cont.)	kW(HP)	-	18.5/15 (25/20.1) [High Torque Motor]
	Live Tool Torque	N-m (lbf-ft)	-	769 (567.2)
TABLE	Table Size	mm(in)	Ø1,000 (Ø39.4")	Ø1,600 (Ø63")
	Table Speed	r/min	492	258 [258]
	Table Max. Torque	N-m (lbf-ft)	8,035 (5,926.3)	22,096 (16,297.2) [23,242 (17,142.4)]
	Table Power (Max./Cont.)	kW(HP)	37/30 (50/40)	37/30 (50/40) [45/37 (60/450)]
ATC	Number of Tools	EA	12 [16] (Turning 12 [16])	18 (Turning 10 + Milling 7 + Dummy 1)
	Tool Size	OD./ID.	mm(in)	□32 (□1.3")/□22 (□0.9")
POWER	Electric Power Supply	kVA	45	65
MACHINE	Floor Space (L×W)	mm(in)	3,685×3,276 (145.1"×129")	5,683×3,937 (223.7"×155")
	Height	mm(in)	4,336 (170.7")	6,177 (243.2")
	Weight	kg(lb)	14,500 (31,967)	29,000 (63,934)
NC	Controller	-	FANUC 32i-B	

※ Prior consultation is required when applying spindle contouring control for gear driven spindle.

## Standard & Optional

LV1400	
Standard	40" 3 Jaw Hydraulic Chuck   Soft Jaw(1set)   Chuck Clamp Foot Switch   Chuck Open/Close Confirmation Device   Standard Tool Holder Standard Coolant (Nozzle)   Bed Flushing   Coolant Tank   Front Door Inter-Lock   3 Color Call Light   Work Light   Leveling block   Foundation Bolt & Nut
Option	50" 4 Jaw   Independent Chuck   50" 4 Jaw Hydraulic Chuck   Gun Coolant   Chip Conveyor (Hinge)   Chip disposal : Rear, Right   Chip Wagon (Standard 180 ℓ [47.5 gal] Swing 200 ℓ [52.8 gal] Large Size 330 ℓ [87.2 gal])   Q-setter   Air Conditioner   Oil Skimmer   3 Color Call Light & Buzzer   Transformer   Auto Power Off   X, Z Axis Linear Scale   High Column 200mm (7.9")   Air Gun
LV2000MM	
Standard	63" Manual Table   Chuck JAW 4set   Standard Tool Holder   Standard Coolant (Nozzle)   SP, Thru Coolant (10bar [145 psi])   Air Gun   Coolant Tank   Front Door Inter-Lock   3 Color Call Light   Work Light   Leveling block   Foundation Bolt & Nut   X,Z Axis Linear Scale   Bed Flushing
Option	SP, Thru Coolant (20bar [290 psi])   Gun Coolant   Chip Conveyor (Hinge)   Chip disposal : Rear, Right   Chip Wagon (Standard 180 ℓ [47.5 gal] Swing 200 ℓ [52.8 gal] Large Size 330 ℓ [87.2 gal])   Q-setter   Air Conditioner   Oil Skimmer   3 Color Call Light & Buzzer   Transformer   Auto Power Off

## Standard Tool Holder

LV1400	1084-40-203: FACE HOLDER A(2EA)	1084-40-204: BORING BAR HOLDER (2EA)
	1084-40-205: FACE HOLDER B(1EA)	1084-40-206: FACE HOLDER C(1EA)
	1084-40-207: BORING BAR(1EA)	1084-40-208: BORING BAR(1EA)
LV2000MM	1085-40-201: FACE HOLDER A(2EA)	1085-40-204: BORING BAR HOLDER (2EA)
	1085-40-305: BORING BAR (1EA)	1085-40-306: BORING BAR (1EA)

Specifications are subject to change without notice for improvement.

# CONTROLLER

## FANUC 32i-B

[ ] : Option

Controlled axis / Display / Accuracy Compensation	
Control axes	2 axes (X, Z) / 3 axes (X, Z, C) / 4 axes (X, Z, Y, C) 5 axes (X, Z, B, C, A) / 6 axes (X, Z, Y, B, C, A)
Simultaneously controlled axes	2 axes [Max. 4 axes]
Designation of spindle axes	4 axes (1 path), 6 axes (2 path Total)
Least setting Unit	X, Z, Y, B axes : 0.001 mm (0.0001 inch) C, A axes : 0.001 deg
Least input increment	X, Z, Y, B axes : 0.001 mm (0.0001 inch) C, A axes : 0.001 deg
Inch / Metric conversion	G20 / G21
High response vector control	
Interlock	All axes / Each axis
Machine lock	All axes
Backlash compensation	± 0 ~ 9999 pulses (Rapid traverse / Cutting feed)
Position switch	
LCD / MDI	10.4 inch color LCD
Feedback	Absolute motor feedback
Stored stroke check 1	Over travel
Stored stroke check 2, 3	
PMC axis control	
<b>Operation</b>	
Automatic operation (Memory)	
MDI operation	
DNC operation	Needed DNC software / CF card
Program restart	
Wrong operation prevention	
Program check function	Dry run, Program check
Single block	
Search function	Program Number / Sequence Number
<b>Interpolation functions</b>	
Nano interpolation	
Positioning	G00
Linear interpolation	G01
Circular interpolation	G02, G03
Exact stop mode	Single : G09, Continuous : G61
Dwell	G04, 0 ~ 9999.9999 sec
Skip	G31
Reference position return	1st reference : G28 2nd reference : G30 Ref. position check : G27
Thread synchronous cutting	
Thread cutting retract	
Variable lead thread cutting	
Multi / Continuous threading	
<b>Feed function / Acc. &amp; Dec. control</b>	
Manual feed	Rapid traverse Jog : 0~2,000 mm/min (79 ipm) Manual handle : x1, x10, x100 pulses Reference position return
Cutting Feed command	Direct input F code
Feedrate override	0 ~ 200% (10% Unit)
Rapid traverse override	F1%, F25%, 50%, F100%
Override cancel	
Feed per minute	G98
Feed per revolution	G99
Look-ahead block	1 block
<b>Program input</b>	
Tape Code	EIA / ISO
Optional block skip	1 ea
Program stop / end	M00, M01 / M02, M30
Maximum command unit	± 999,999.999 mm (± 99,999.9999 inch)
Plane selection	X-Y : G17 / Z-X : G18 / Y-Z : G19
Workpiece coordinate system	G52, G53, 6 pairs (G54 ~ G59)
Manual absolute	Fixed ON
Programmable data input	G10
Sub program call	10 folds nested
Custom macro	#100 ~ #149, #500 ~ #549
G code system	A
Programmable mirror image	G51.1, G50.1
G code preventing buffering	G41
Multiple repetitive cycles I, II	

<b>Program input</b>	
Canned cycle for turning	
Manual Guide i	Conversational auto program
<b>Auxiliary function / Spindle speed function</b>	
Auxiliary function	M 4 digit
Level-up M Code	High speed / Multi / Bypass M code
Spindle speed function	S 4 digit, Binary output
Spindle override	0% ~ 150% (10% Unit)
Multi position spindle orientation	M19
Rigid tapping	
Constant surface speed control	G96, G97
<b>Tool function / Tool compensation</b>	
Tool function	T 2 digit + Offset 2 digit
Tool life management	
Tool offset pairs	32 pairs
Tool nose radius compensation	G40, G41, G42
Geometry / Wear compensation	
Direct input of offset measured B	
<b>Editing function</b>	
Part program storage size	640m (256KB)
No. of registerable programs	500 ea
Program protect	
Background editing	
Extended part program editing	Copy, move and change of NC program
Memory card program edit	
<b>Data input / output &amp; Interface</b>	
I/O interface	CF card, USB memory Embedded Ethernet interface
Screen hard copy	
External message	
External key input	
External workpiece number search	
Automatic data backup	
<b>Setting, display and diagnosis</b>	
Self-diagnosis function	
History display & Operation	Alarm & Operator message & Operation
Run hour / Parts count display	
Maintenance information	
Actual cutting feedrate display	
Display of spindle speed / T code	
Graphic display	
Operating monitor screen	Spindle / Servo load etc.
Power consumption monitoring	Spindle & Servo
Spindle / Servo setting screen	
Multi language display	Support 20 languages
Display language switching	Selection of 5 optional Languages
LCD Screen Saver	Screen saver
Unexpected disturbance torque	BST (Back spin torque limit)
<b>Function for machine type</b>	
Cs contour control (C & A axes)	Mill, MS, Y, SY, LF-Mill, TTMS, TTSY
Polar coordinate interpolation	Mill, MS, Y, SY, LF-Mill, TTMS, TTSY
Cylindrical interpolation	Mill, MS, Y, SY, LF-Mill, TTMS, TTSY
Canned cycle for drilling	Mill, MS, Y, SY, LF-Mill, TTMS, TTSY
Spindle orientation expansion	MS, SY TTS, TTMS, TTSY
Spindle synchronous control	MS, SY TTS, TTMS, TTSY
Torque control	MS, SY TTS, TTMS, TTSY
Y axis offset	Y, SY, TTSY
Arbitrary angular control	Y, SY, TTSY
Composite / Superimposed control	MS, SY TTS, TTMS, TTSY
Balance cutting	MS, SY TTS, TTMS, TTSY
<b>Option</b>	
Additional optional block skip	9 ea
Fast ethernet	Needed option board
Data server	Needed option board
Protection of data at 8 levels	
Tool offset pairs	64 pairs / 99 pairs / 200 pairs
Part program storage size	1280 m (512KB) / 2560m (1MB)
Polygon turning (2 Spindles)	Mill, MS, Y, SY, LF-Mill, TTMS, TTSY
Helical interpolation	
Dynamic graphic display	
Direct drawing dimension program	Including Chamfering / Corner R

Figures in inch are converted from metric values.

The FANUC controller specifications are subject to change based on the policy of company CNC supplying.

# HYUNDAI WIA ECO SYSTEM

## MQL (Minimal Quantity Lubrication)

The goal of this system is to spray only the amount of lubricant required to prevent heat and chip build up at the cutting tool or work piece face.

### Example of Turning Center Application

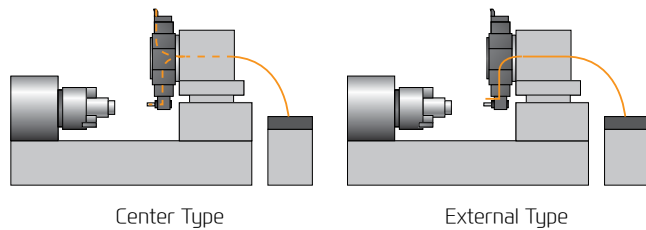

### Example of Etc.

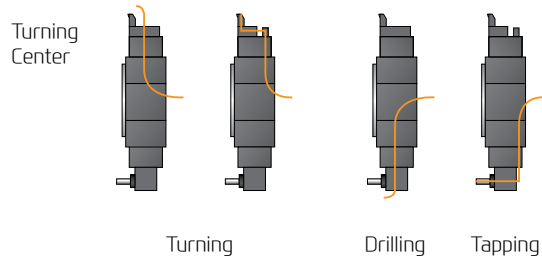

Oil Skimmer

An oil skimmer can increase coolant and tool life by removing tramp oil contaminants.



Mist Collector

Mist Collector reduces the amount of smoke and oil mist in the air. This helps build a safe and comfortable working environment and improve durability.

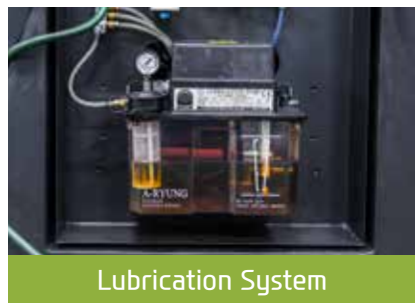

Lubrication System

By applying lubricant only when the machines axis are moving lubrication consumption is reduced by compared to standard systems.

# HYUNDAI WIA ENERGY SAVING

## HW-ESS (HYUNDAI WIA Energy Saving System)

HYUNDAI WIA Machine tool provides the optimum power saving function that can easily save energy with an intuitive user interface.



1. **Machine-ready power saving function** : Put all servo motors and other motors into sleep mode when no control or operation is done for a set time
2. **Work light auto-off function** : The work light is turned off automatically when no control or operation is done for a set time
3. **Chip conveyor auto power saving** : Operation/non operation time (timer) can be set to save energy
4. **Auto Power-off** : Auto power off after ending the an operation after a period of time
5. **Eco function** : Machine ready sleep mode can be activated/de-activated from the controller panel
6. **Power consumption monitor** : Real time power consumption can be monitored through the OP screen



LV1400  
Movie



LV2000MM  
Movie



**You Tube** HYUNDAI WIA MT

[www.youtube.com/HYUNDAIWIAMT](http://www.youtube.com/HYUNDAIWIAMT)

## EXPERIENCE THE NEW TECHNOLOGY

With its top-quality HYUNDAI WIA machine tool creates a new and better world.



<http://machine.hyundai-wia.com>

HYUNDAI WIA Machine Tools  
Global Links

### HEADQUARTER

**Changwon Technical Center/R&D Center/Factory** 153, Jeongdong-ro, Seongsan-gu, Changwon-si, Gyeongsangnam-do, Korea TEL : +82 55 280 9114 FAX : +82 55 282 9114

**Overseas Sales Team /R&D Center** 37, Cheoldobangmulgwan-ro, Uiwang-si, Gyeonggi-do, Korea TEL : +82 31 8090 2539

### OVERSEAS OFFICES

**HYUNDAI WIA Machine America corp.** 450 Commerce Blvd, Carlstadt, NJ 07072, USA TEL : +1-201-987-7298

**HYUNDAI WIA Europe GmbH** Alexander-Fleming-Ring 57, 65428 Rüsselsheim Germany TEL : +49-0-6142-9256-0

**HYUNDAI WIA Machine Tools China** 2-3F, Bldg6, No.1535 Hongmei Road, Xuhui District, Shanghai, China TEL : +86-21-6427-9885

**India Branch Office** #4/169, 1st Floor, LOTTE BLDG, Rajiv Gandhi Salai, (OMR), Kandanchavadi, Chennai - 600096, Tamilnadu, India TEL : +91-76-0490-3348